



N. GIOVA

N. GIOVA



*Inspired by European Classics*

## MANTELS, KITCHEN HOODS, COLUMNS & PANELS

Since 1981 Omega Mantels has been providing luxury retailers across North America with an extensive selection of distinctive, hand crafted artisanal fireplace mantels, ornamental plaster and cast stone products. All proudly manufactured in Canada.

Introducing our Volume 3 Catalogue, featuring an extensive collection of fireplace mantels and overmantels as well as a modest representation of Omega's exquisite hand crafted cast stone products, each uniquely customized to reflect individual creative expressions while offering products to accommodate every budget.

Omega Mantels is an industry leader and the destination of choice for all your cast stone needs. Drawn from European classical inspiration, while reflecting modern day taste, Omega's core mantel and overmantel designs are equally mirrored and celebrated with our kitchen hoods, columns, panels and ornamental moulding collections.

The passion, determination and commitment make Omega the premier manufacturer of quality cast stone and plaster products.

Omega's proprietary methods of creating cast stone products with the look and texture of natural stone enable Omega to customize dimensions, style and size to accommodate virtually all situations and manufacture unique one of a kind pieces. Expertly constructed with lightweight cast stone, Omega's extensive collection of moulds and finishes provide a variety of design options ranging from clean modern lines to the most intricate and ornate of sculpture. Whether you prefer a more traditional mantel adorned with elaborate curves and details, or the simplistic clean lines of a more contemporary style, each individual piece is hand crafted by true artisans, using time honoured old world techniques. Available in 3 distinct finishes, Open Cast, Diamond or Honed (available with veining, or polished to resemble earth stones such as marble, granite or limestone), with a choice of 9 colours to provide the perfect finish for your new piece.

For over 30 years Omega Mantels has successfully collaborated with builders, architects and designers on an extensive range of projects, from home renovations to large scale commercial spaces. At Omega, each creation is designed and built to your unique requirements, customized to suit each individual project, home, or space from residential to commercial and industrial. Trusted and renowned for our exceptional quality and services that include custom design for residential, retail and corporate projects, Omega Mantels guarantees craftsmanship that truly echoes iconic and artistic quality. From inspiration and design, to manufacturing and installation, each masterpiece is created by true artisans and resonates equally with luxury and quality.

Inviting spaces inspired by moments of creativity, celebrated and delivered by unsurpassed commitment to quality.

Omega Mantels....Redefining the landscape of architectural beauty and mastery with true artisanal craftsmanship...

Allow Omega's journey of innovation in the evolution of cast stone products to bring you to cast stone perfection.



Rose Montagnese, Company Founder

SEAMLESS  
CUSTOM

# INDEX

- **CLASSIC MANTELS** | PAGE 4 to PAGE 17
- **CLASSIC MANTELS & OVERMANTELS** | PAGE 18 to PAGE 35
- **TRADITIONAL MANTELS** | PAGE 36 to PAGE 50
- **TRADITIONAL MANTELS & OVERMANTELS** | PAGE 51 to PAGE 65
- **TRANSITIONAL/CONTEMPORARY MANTELS** | PAGE 66 to PAGE 78
- **TRANSITIONAL/CONTEMPORARY MANTELS & OVERMANTELS** | PAGE 79 to PAGE 85
- **SLABS/STACKED STONE** | PAGE 86 to PAGE 95
- **GRANDSTOCK SERIES MANTELS** | PAGE 96 to PAGE 107
- **HEARTH AND INSETS** | PAGE 108 to PAGE 109
- **LEGS & SHELVES DIMENSIONS** | PAGE 110 to PAGE 114
- **ANATOMY OF A FIREPLACE** | PAGE 115
- **KITCHEN HOODS** | PAGE 116 to PAGE 123
- **COLUMNS & PANELS** | PAGE 124 to PAGE 133
- **FIREPIT TABLES** | PAGE 134 to PAGE 137
- **3D WALL PANELS** | PAGE 138 to PAGE 141
- **FEATURE MOULD** | PAGE 142 to PAGE 145
- **PRODUCT CARE AND MAINTENANCE** | PAGE 146
- **COLOURS AND FINISHES** | LOCATED ON INSIDE BACK COVER

## SHELVES

- 1104 | PG 14
- 1106 | PG 17, 19, 21, 24, 31, 33, 35, 59, 64, 97, 98, 99
- 1106.11 | PG 9
- 1108 | PG 57, 65
- 1110 | PG 6, 8, 23, 25, 28, 30, 100, 101
- 1110.FLUTE | PG 16
- 1110.LEAF | PG 43
- 1110.SCROLL | PG 41, 102, 103
- 1110.SHELL | PG 44
- 1111 | PG 29, 104, 105
- 1112 | PG 48
- 1126 | PG 34
- 1127 | PG 45
- 1130.70 | PG 10, 11
- 1130.80 | PG 11
- 1135 | PG 50
- 1136 | PG 52, 55, 56, 60, 62, 63
- 1136.11 | PG 47
- 1141 | PG 46
- 1142 | PG 53
- 1143 | PG 7
- 1144 | PG 22, 32, 54
- 1144.11 | PG 15
- 1145 | PG 42, 58
- 1147 | PG 26, 27, 106, 107
- 1152 | PG 49
- 1160 | PG 61

## LEGS

- 511 | PG 29, 99, 101, 103, 104, 105, 106, 107
- 524 | PG 46, 53, 63
- 527 | PG 14
- 529 | PG 41
- 530 | PG 12, 13
- 531 | PG 10, 11
- 533 | PG 48, 54
- 534 | PG 42, 43, 58
- 535 | PG 15
- 536 | PG 7, 17, 21, 24, 31, 33, 57, 59, 64, 65, 97, 98, 99, 101, 103, 105, 107
- 536L | PG 19, 35
- 537 | PG 50
- 538 | PG 8, 9
- 540 | PG 61
- 545 | PG 47
- 546 | PG 49
- 548 | PG 52, 55, 56, 60
- 555 | PG 34, 62, 99, 101, 103, 105, 107
- 556 | PG 6, 23, 25, 30, 98, 100, 102, 104, 106
- 557 | PG 16, 28, 44
- 577 | PG 22, 32, 45
- 599 | PG 26, 27

## ONE PIECE MANTELS

- 1100 | PG 38
- 1101 | PG 40
- 1107 | PG 39
- 1113 | PG 70, 71, 84
- 1114S & 1114L | PG 77
- 1115.7 & 1115.11 | PG 74, 80
- 1116 | PG 72, 95
- 1119 | PG 81
- 1120 | PG 67
- 1121 | PG 82
- 1122 | PG 89
- 7701 | PG 73
- 7702 | PG 75
- 7703 | PG 76
- 7704 | PG 85
- ATLANTA | PG 78
- CHATEAU | PG 20
- STACKED STONE/SLABS | PG 68, 69, 87, 88, 89, 90, 91, 92, 93, 94, 95

## OVERMANTELS

- AZZURO | PG 65
- CALEDON | PG 21, 62
- CAPRI | PG 23, 26, 29, 31, 54, 80, 84
- CHATEAU | PG 20
- CLASSIC | PG 25, 28, 30, 35
- COLONIAL | PG 57
- CORTESSA | PG 27
- DAKOTA | PG 81
- FRESNO | PG 22, 32
- MADISON | PG 82
- MONACO | PG 64
- REGAL | PG 24, 55, 56, 60, 63, 83
- ROYAL | PG 52, 53, 58
- SOHO | PG 85
- TREVI | PG 33, 34, 59
- TUSCAN | PG 19
- VALENCIA | PG 61

Printing, JBS Graphic Communications Inc.  
Photography by Bøje Pedersen, Jstar Digital  
Pencil Sketches by Natasha Orlova

Due to the nature of the product please allow for 1/4" dimension tolerance.

*Classic Series*

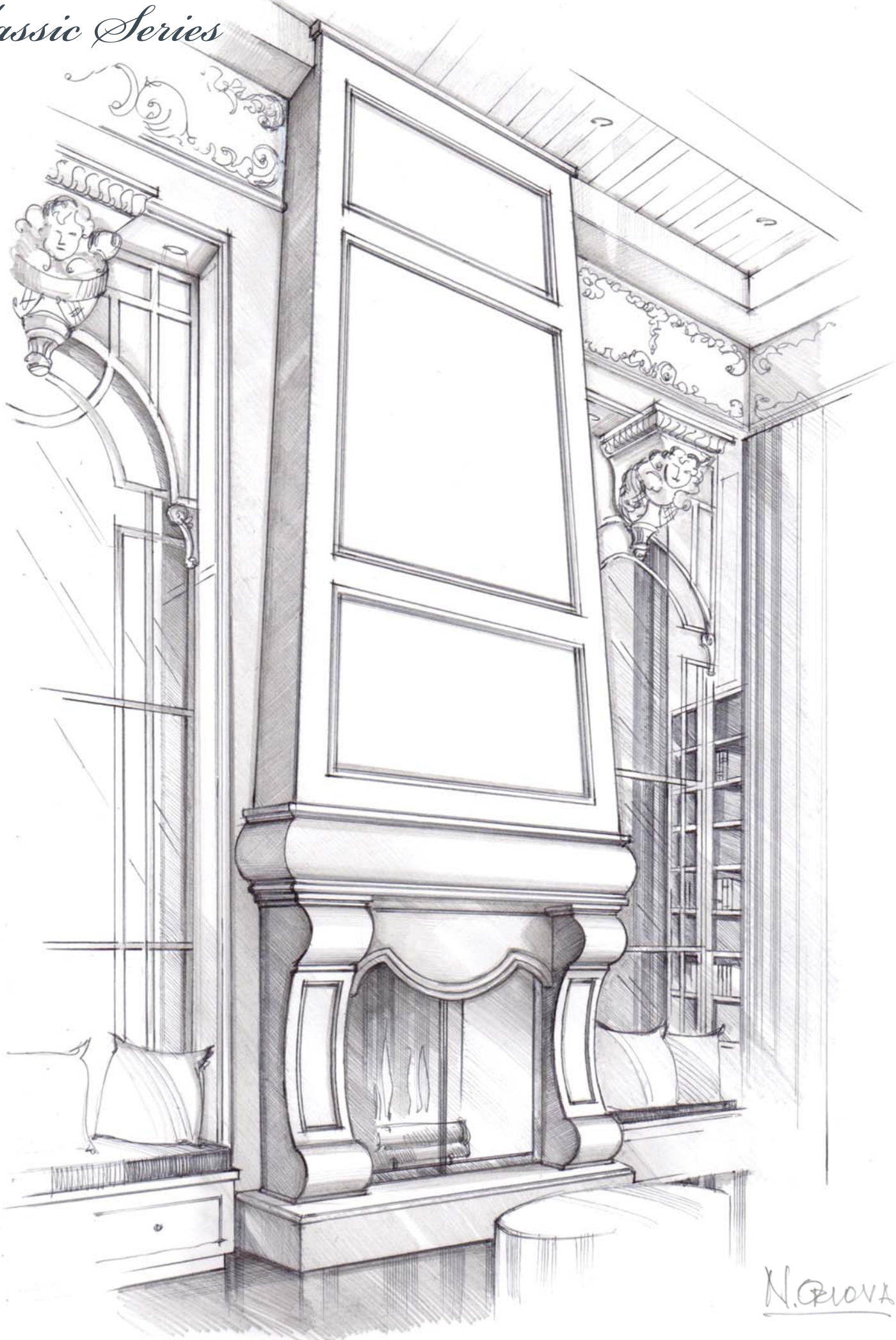

*N. GIOVA*



LORI MORRIS™

**CUSTOM DESIGN MANTEL AND OVERMANTEL**

SHOWN IN CUSTOM COLOUR



1110.556

SHOWN IN NATURAL OPEN CAST



SHOWN IN SAHARA VEINED HONED

1143.536

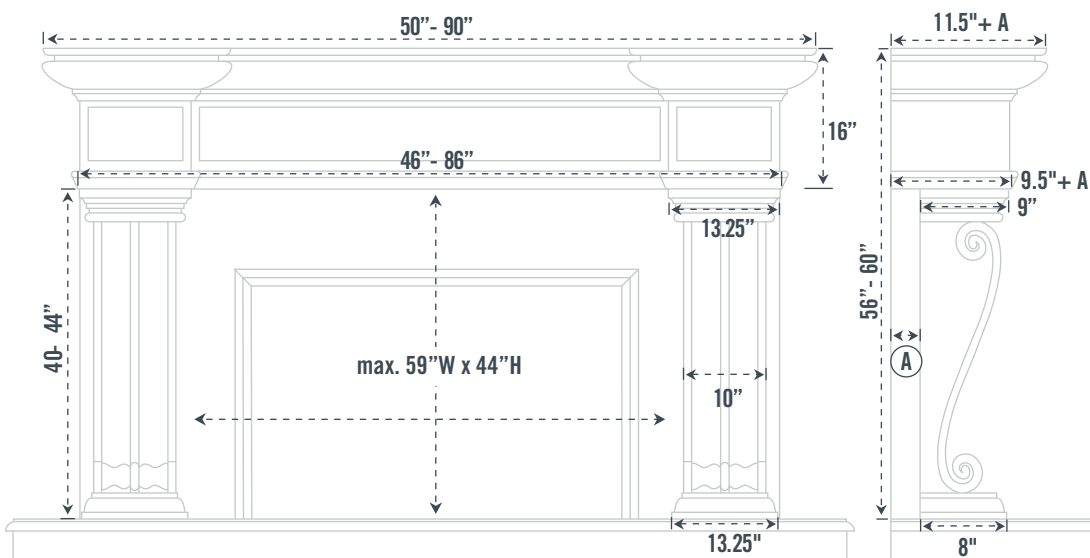



SHOWN IN CHOCOLATE HONED

1110.538

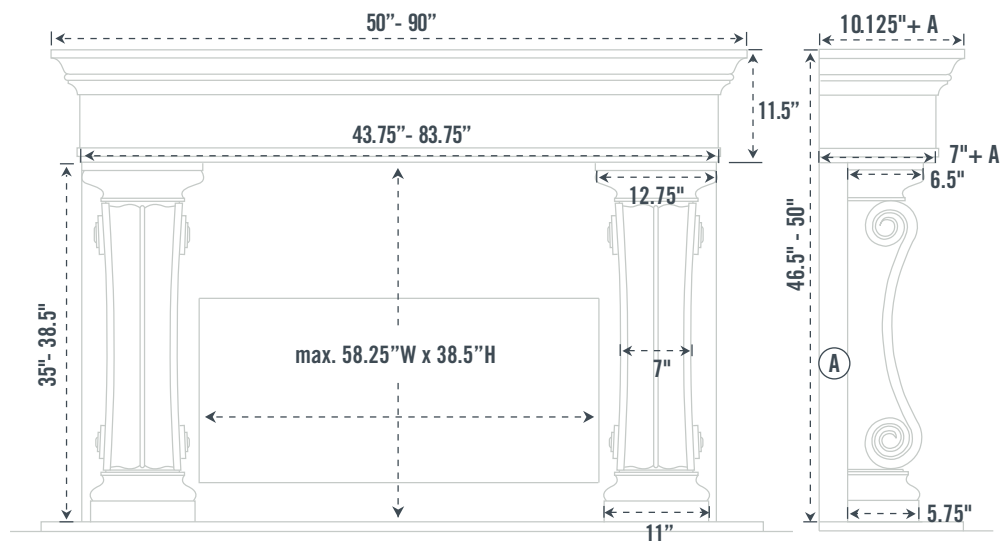





SHOWN IN LIMESTONE OPEN CAST

**1106.11.538**  
**INCL. PLINTH BLOCK**

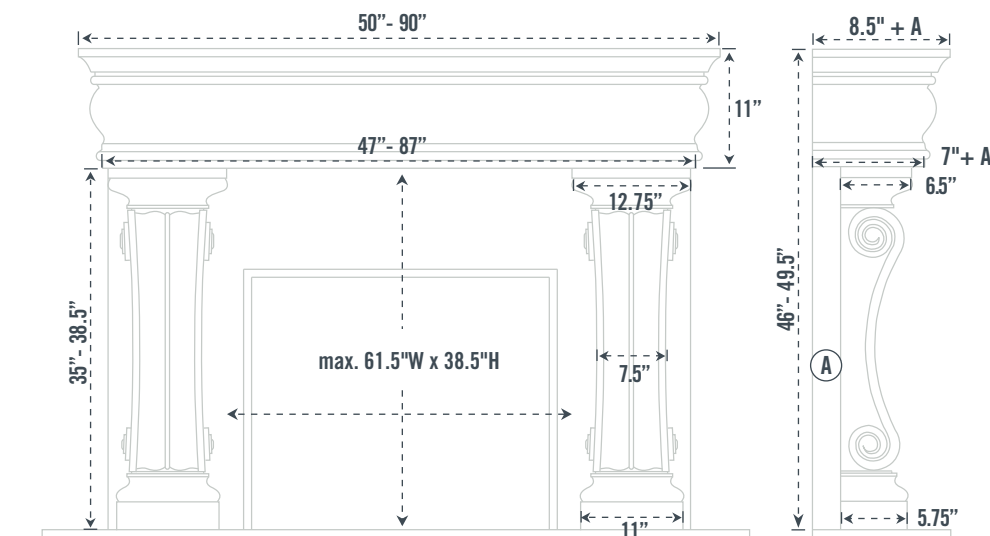



1130.70.531

SHOWN IN NATURAL OPEN CAST

# 1130.70.531 CUSTOM

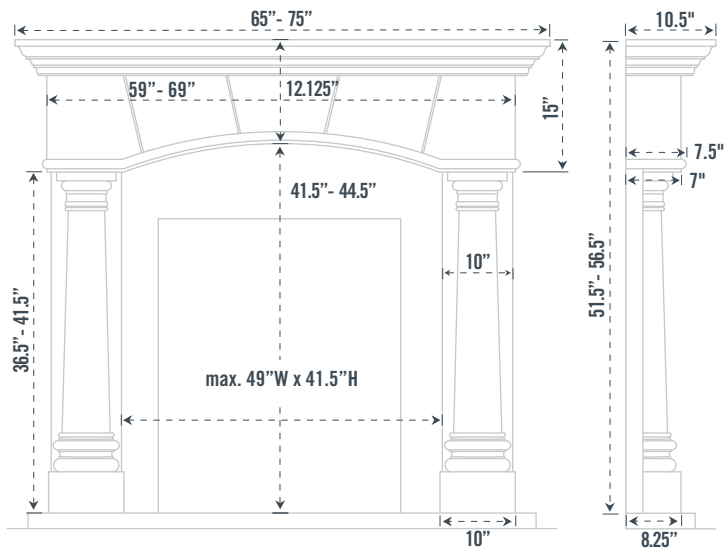

# 1130.70.531 STANDARD

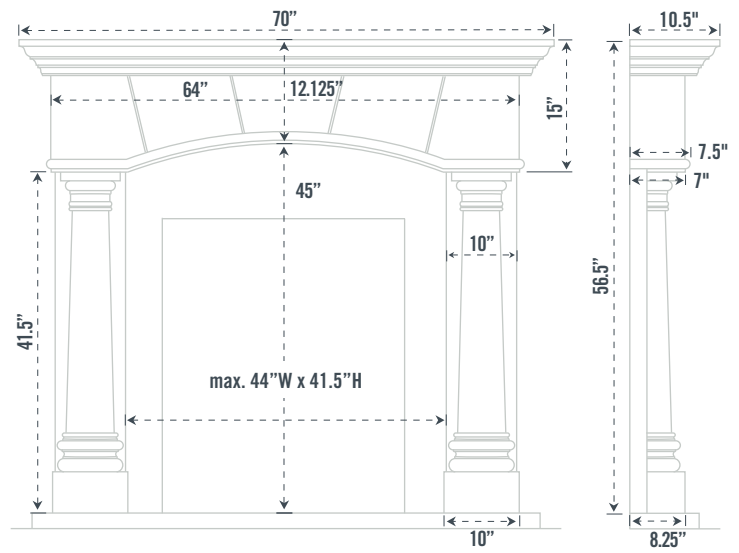

# 1130.80.531 CUSTOM

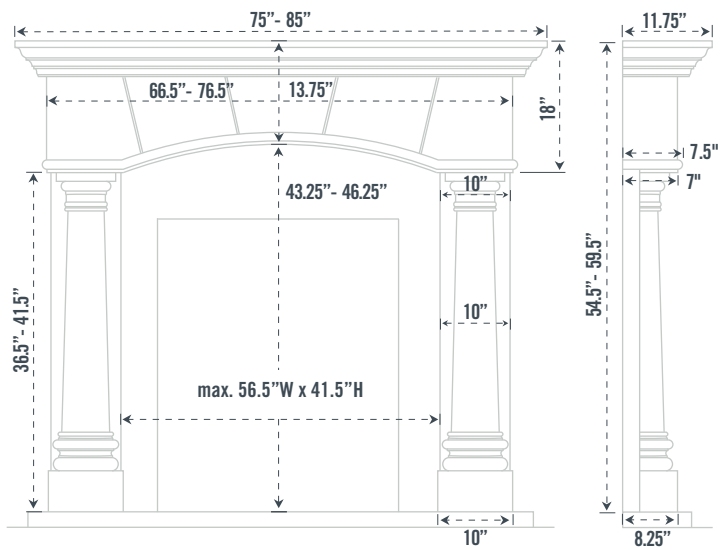

# 1130.80.531 STANDARD

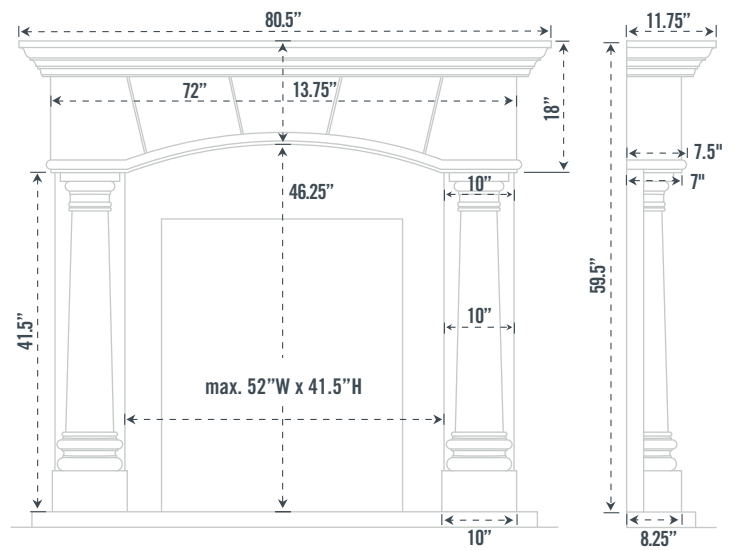



1130.70.530

SHOWN IN NATURAL OPEN CAST

## 1130.70.530 CUSTOM

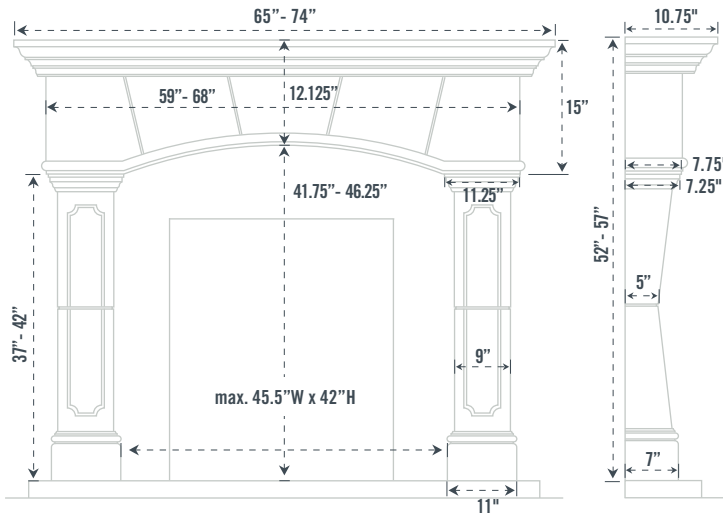

## 1130.70.530 STANDARD

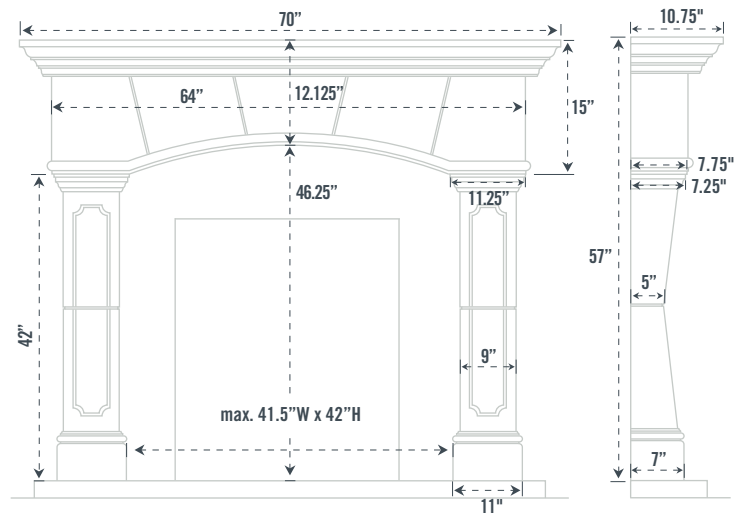

## 1130.80.530 CUSTOM

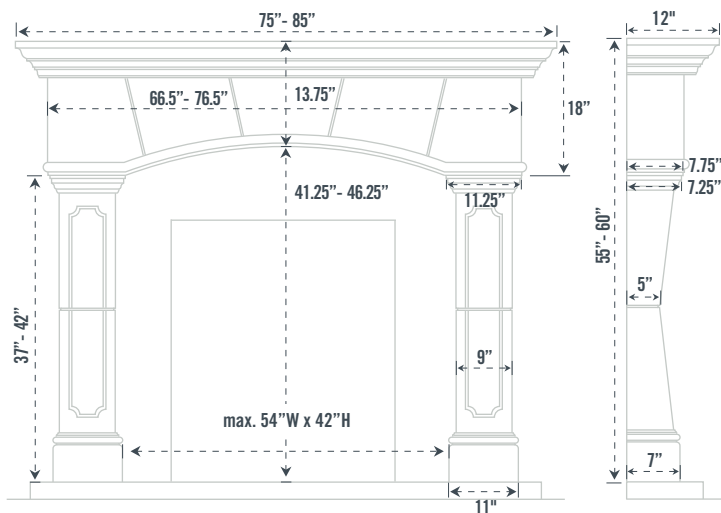

## 1130.80.530 STANDARD

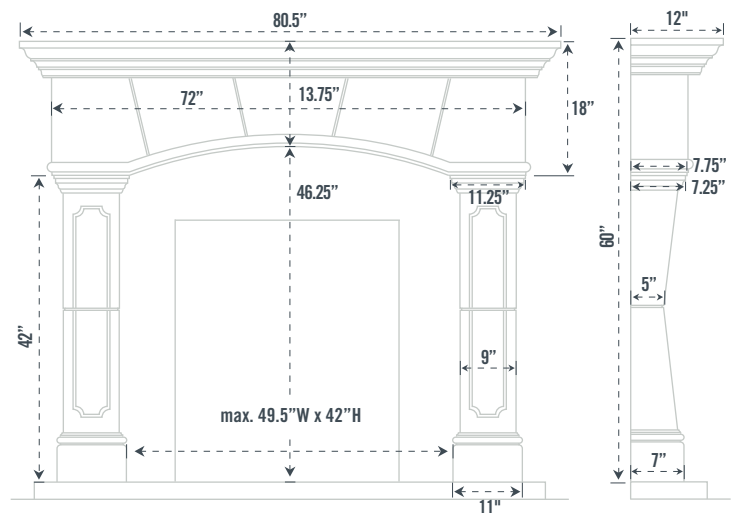



SHOWN IN NATURAL OPEN CAST

**1104.527**

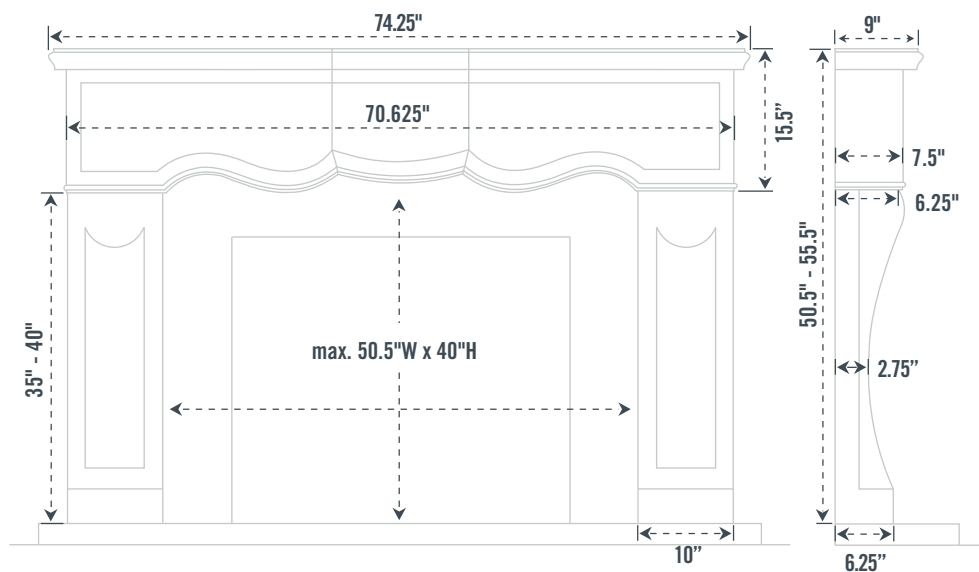



SHOWN IN PEARL VEINED HONED

**1144.11.535**

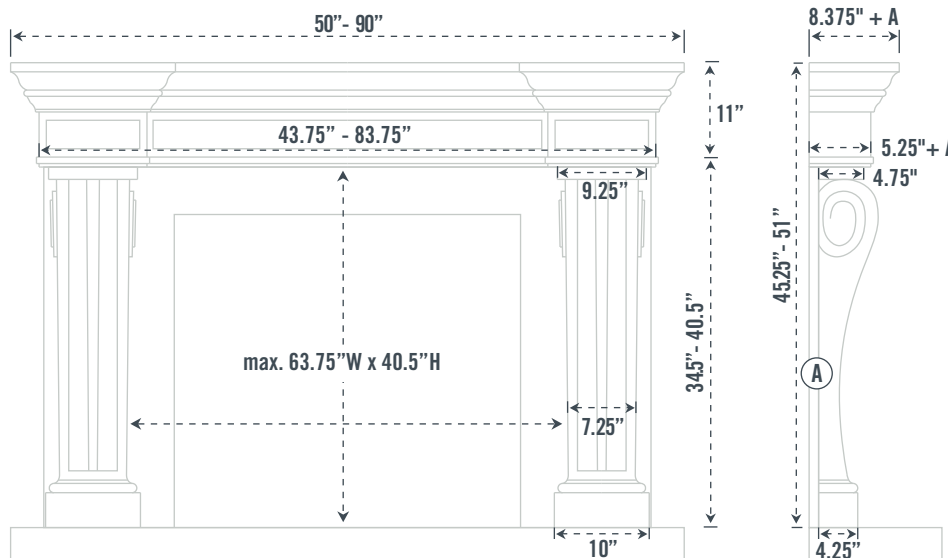



SHOWN IN SAHARA HONED

# 1110.FLUTE.557

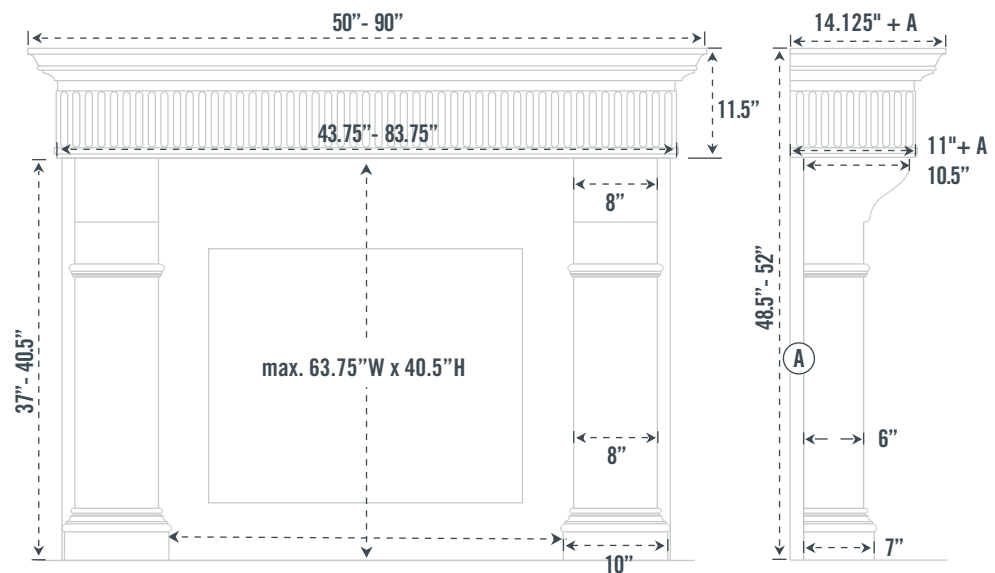





SHOWN IN SAHARA VEINED HONED WITH STEEL MILL ACCENTS

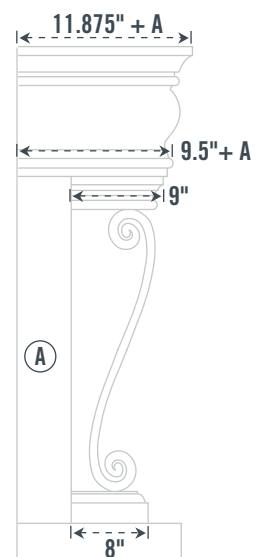
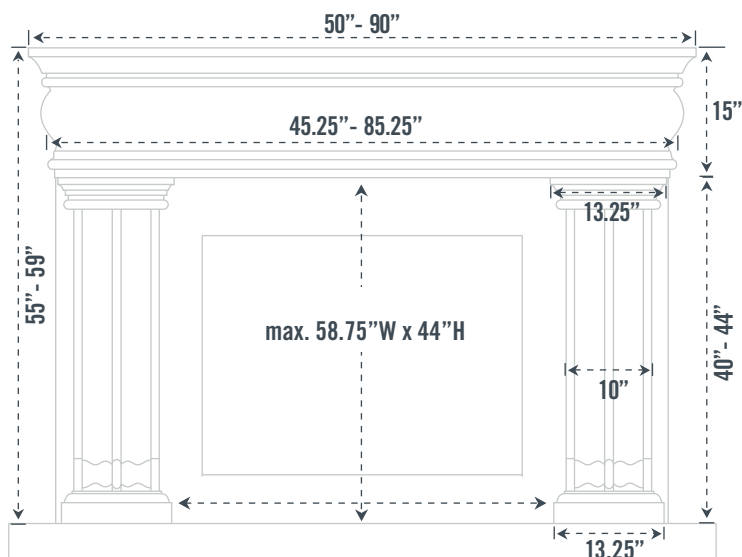

**1106.536**

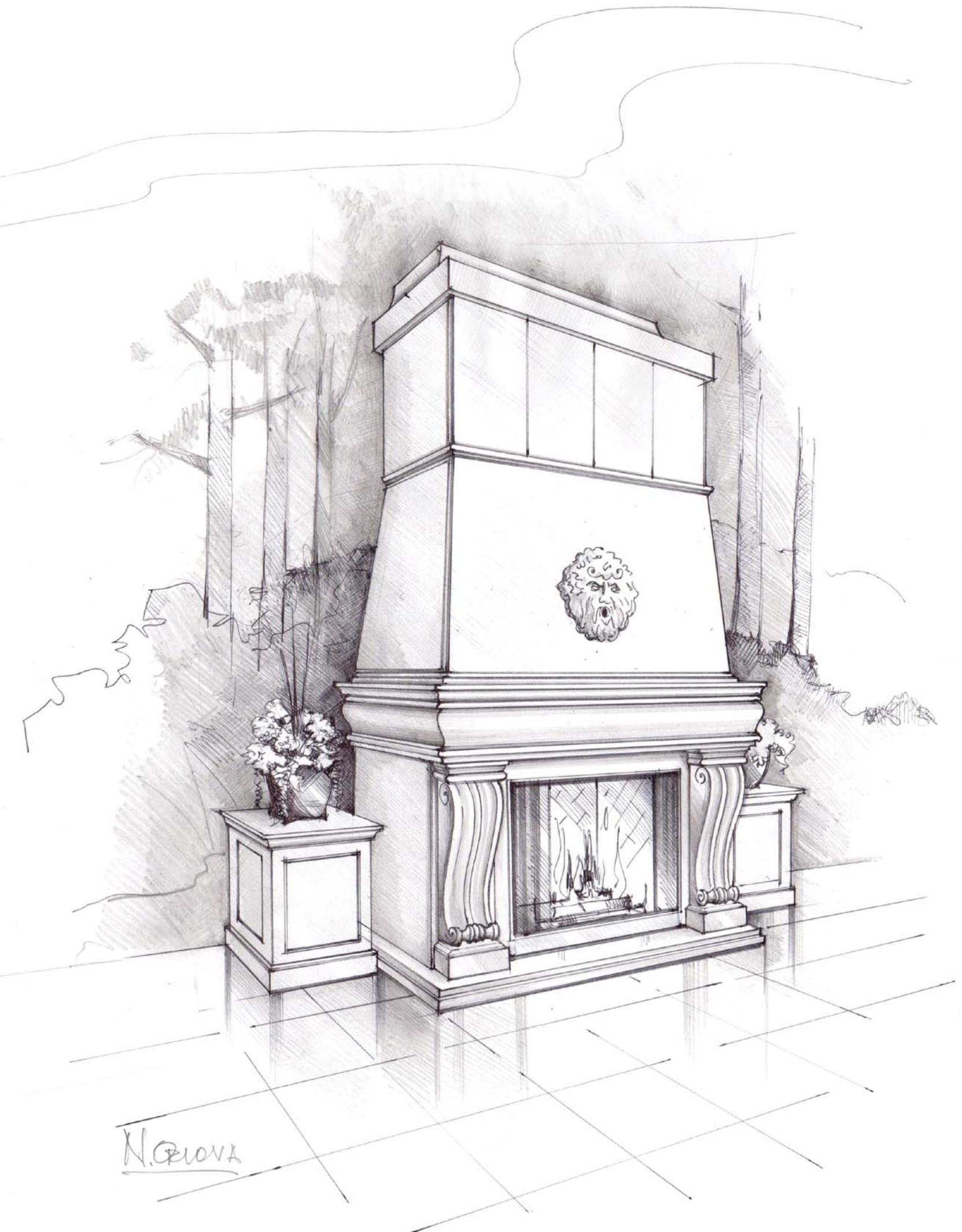

N. GIOVA

# 1106.536L TUSCAN OVERMANTEL

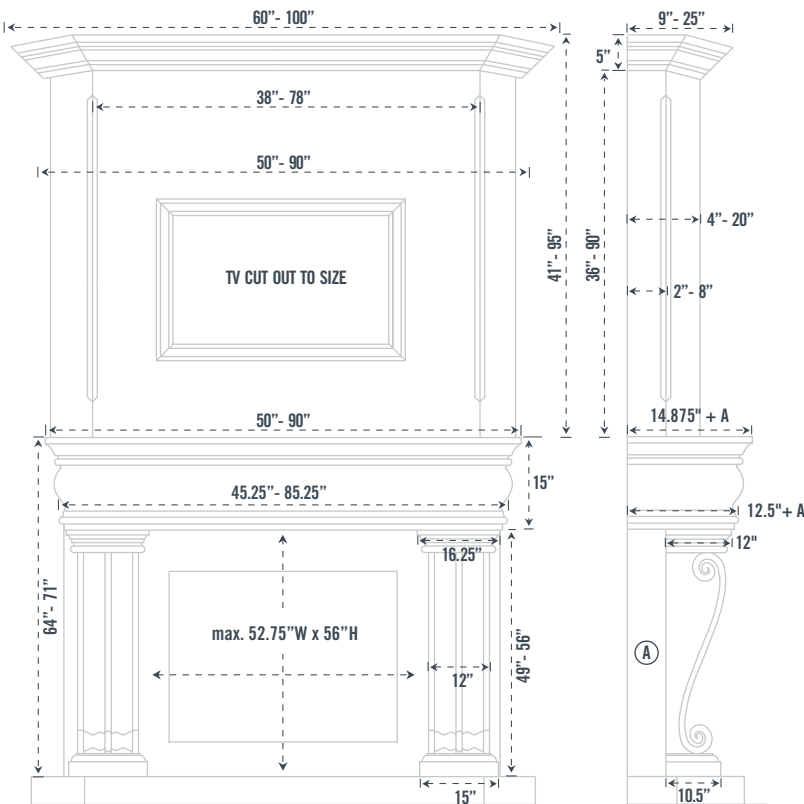

SHOWN IN SAHARA VEINED HONED WITH STEEL MILL ACCENTS

# Chateau

## CHATEAU OVERMANTEL

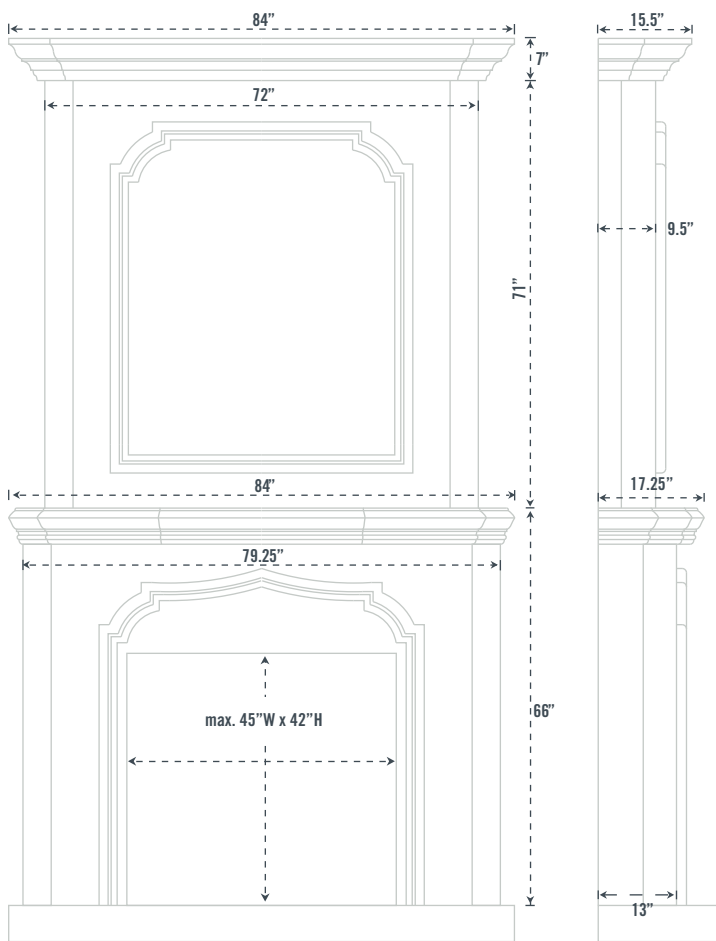

SHOWN IN PEARL HONED



**1106.536**

CALEDON OVERMANTEL INCL. CUSTOM SIDE CABINETS

SHOWN IN ASH HONED



**1144.577**

FRESNO OVERMANTEL INCL. CUSTOM SIDE CABINETS

SHOWN IN PEARL HONED



**1110.556**

**CAPRI OVERMANTEL INCL. CUSTOM SIDE CABINETS**

SHOWN IN SAHARA HONED



# 1106.536

INCL. 1110 SECONDARY MANTEL  
AND CUSTOM REGAL OVERMANTEL

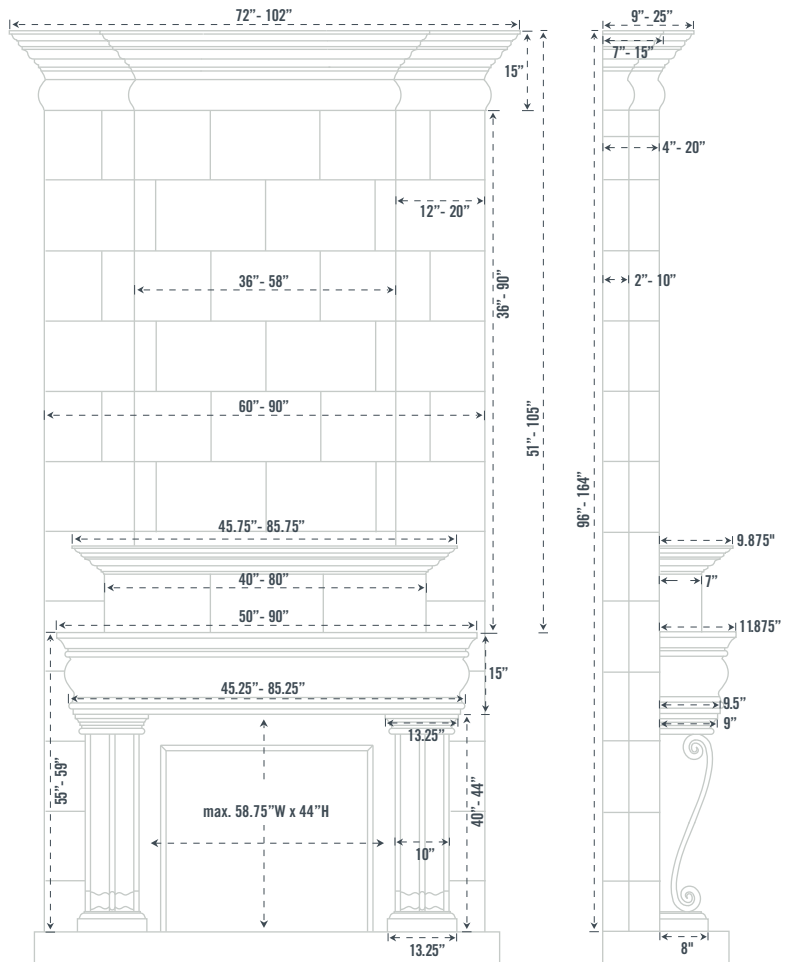

SHOWN IN SAHARA VEINED HONED



# 1110.556

## CUSTOM CLASSIC OVERMANTEL

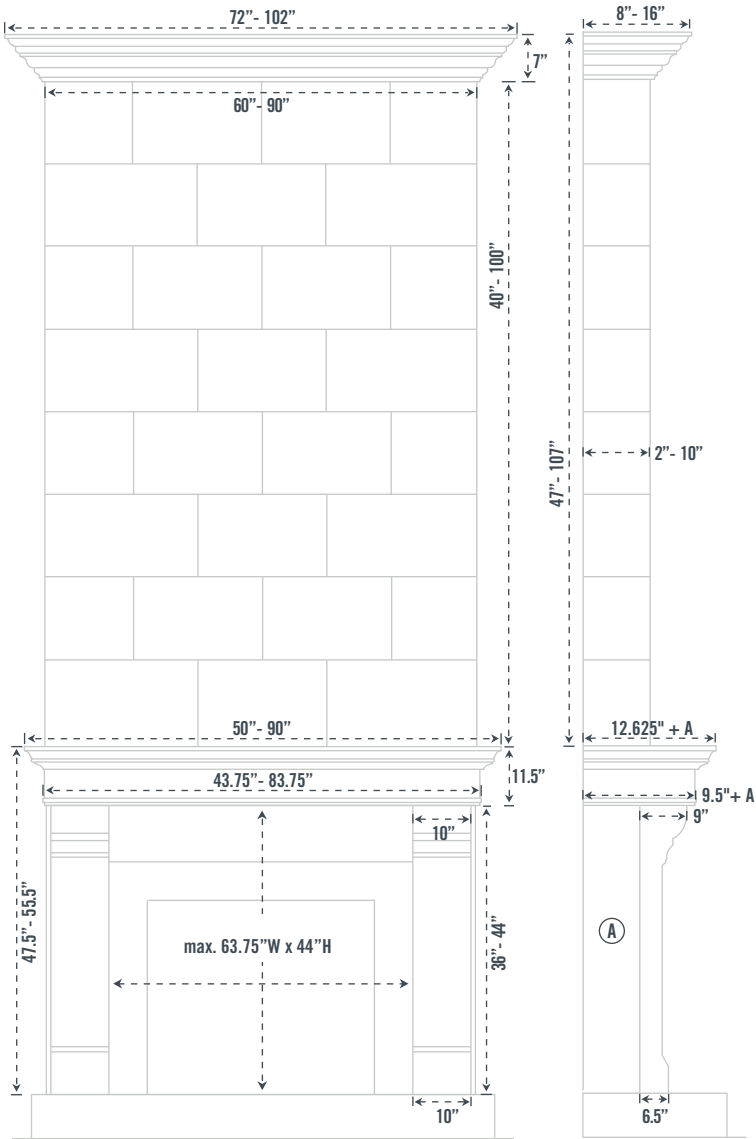

SHOWN IN NATURAL OPEN CAST

# 1147.599

## CAPRI OVERMANTEL INCL. TV NICHE & TRIM

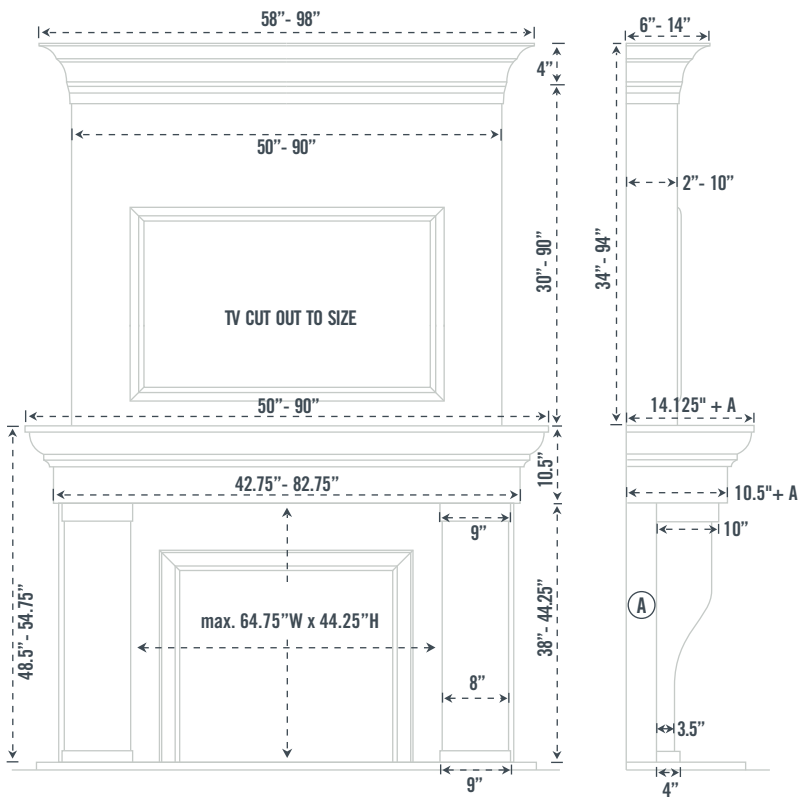

SHOWN IN SAHARA VEINED HONED WITH STEEL MILL ACCENTS



# 1147.599

## CORTESSA OVERMANTEL

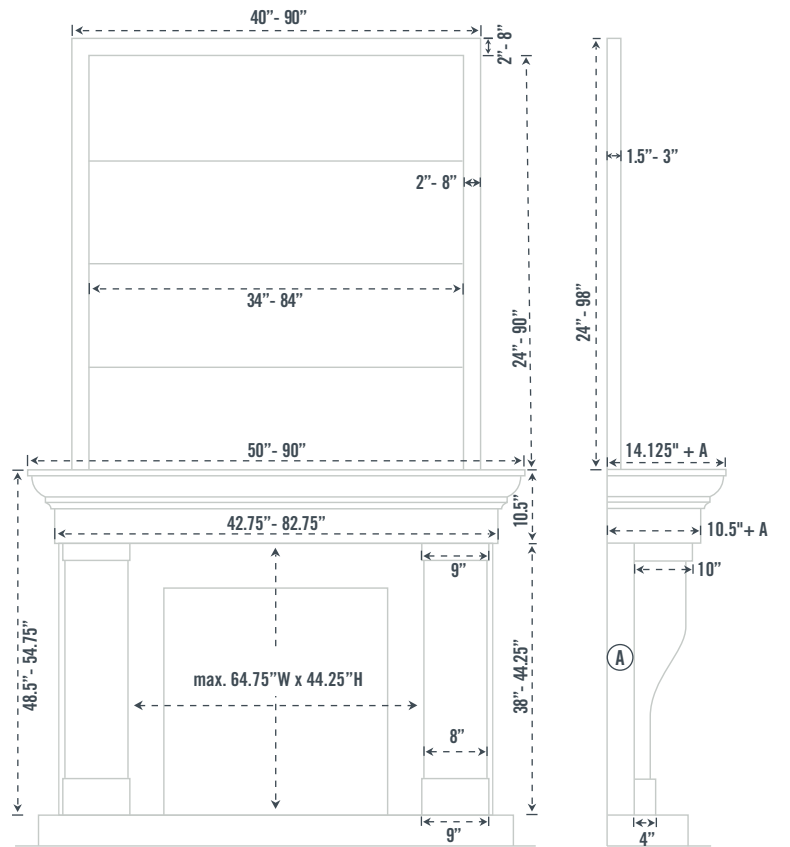

SHOWN IN CHOCOLATE HONED



**1110.557**  
CUSTOM CLASSIC OVERMANTEL

SHOWN IN LIMESTONE OPEN CAST



**1111.511 CABINET**  
CAPRI OVERMANTEL INCL. RECESS

SHOWN IN CUSTOM BLACK HONED



**1110.556 CABINET**  
CUSTOM CLASSIC OVERMANTEL

SHOWN IN PEARL VEINED HONED



**1106.536**  
CAPRI OVERMANTEL

SHOWN IN CUSTOM BLACK HONED

# 1144.577

## FRESNO OVERMANTEL

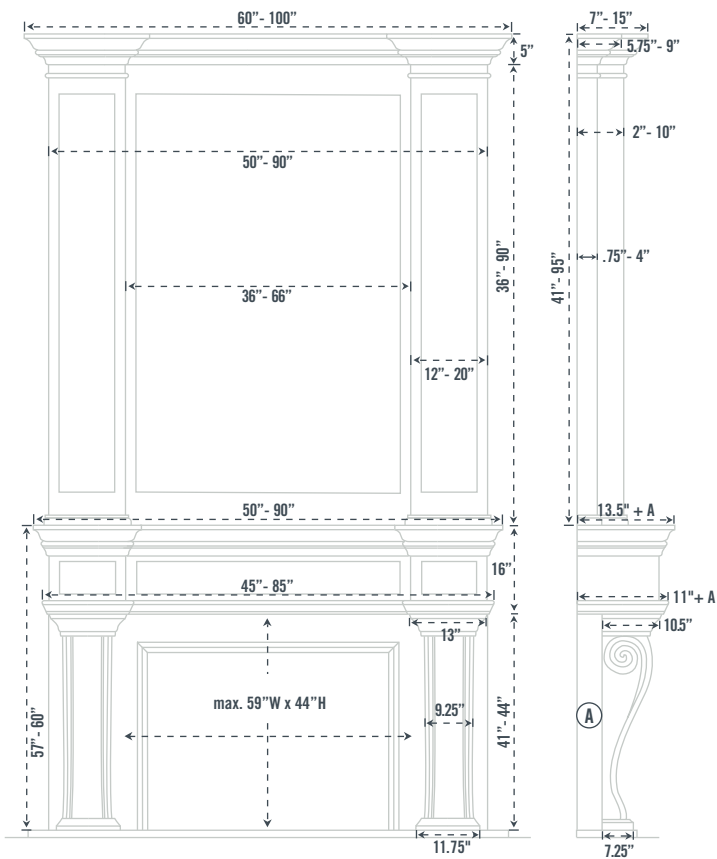

SHOWN IN SAHARA VEINED HONED





**1106.536**

CUSTOM TREVI OVERMANTEL INCL. TV NICHE

SHOWN IN SAHARA HONED



# 1126.555

## TREVI OVERMANTEL

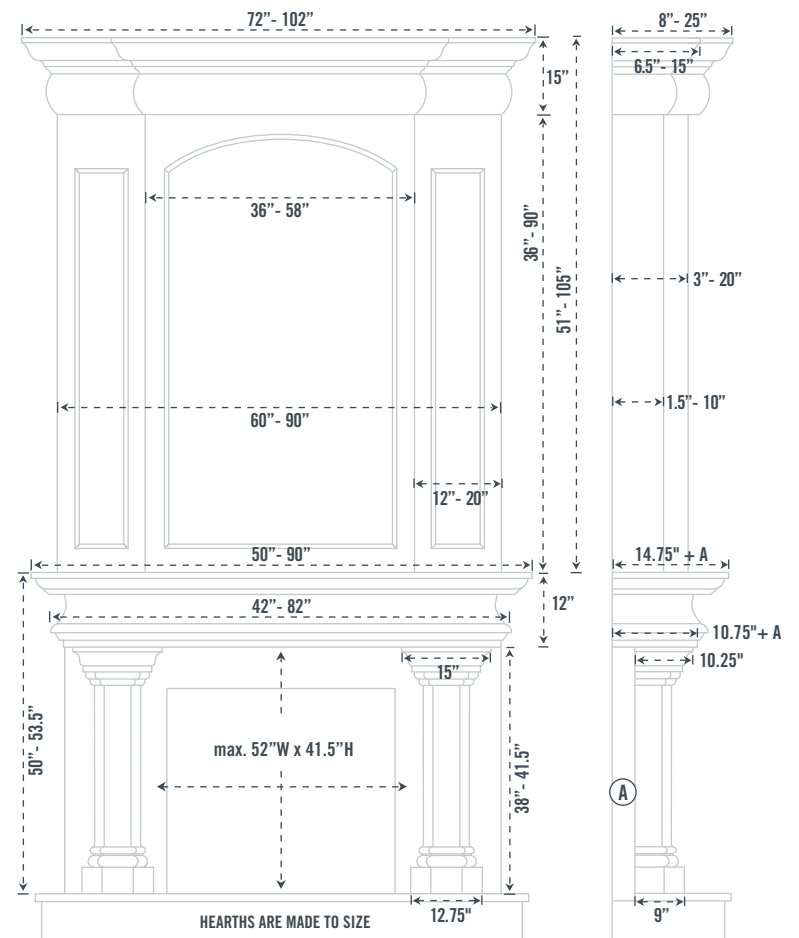

SHOWN IN CHOCOLATE DIAMOND STONE

# 1106.536L

## CLASSIC OVERMANTEL

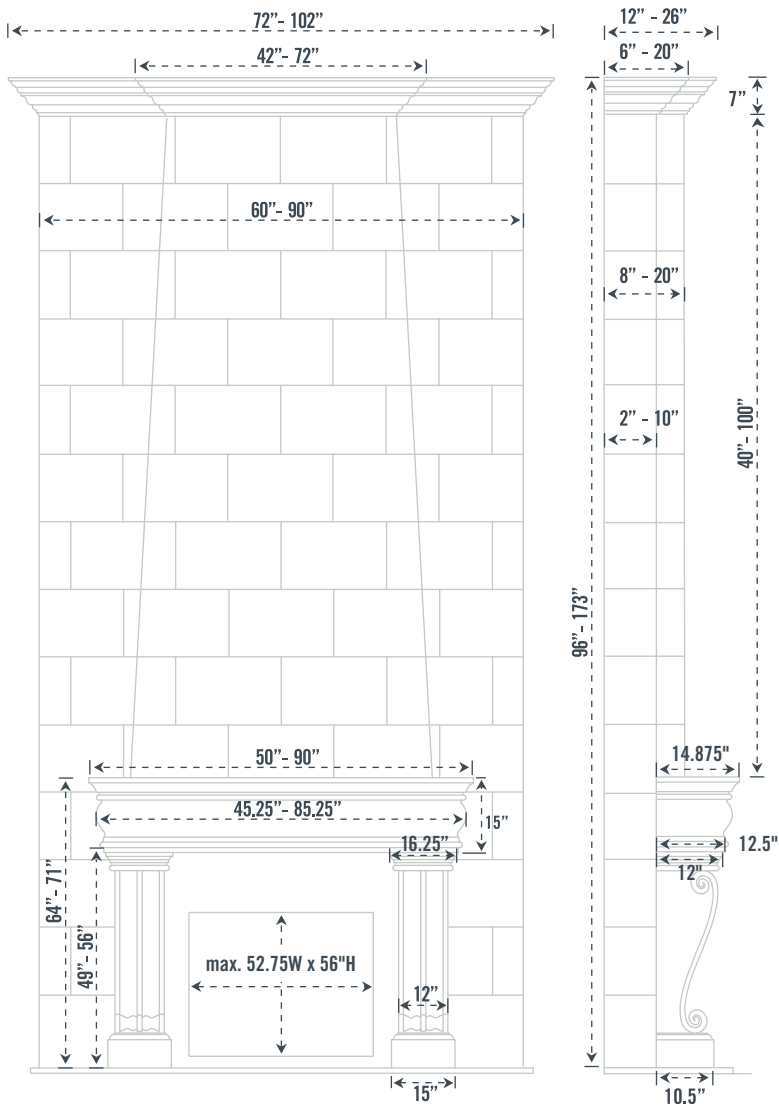

Panel sizes are customized to suit your requirements.



SHOWN IN SAHARA VEINED HONED

# *Traditional Series*

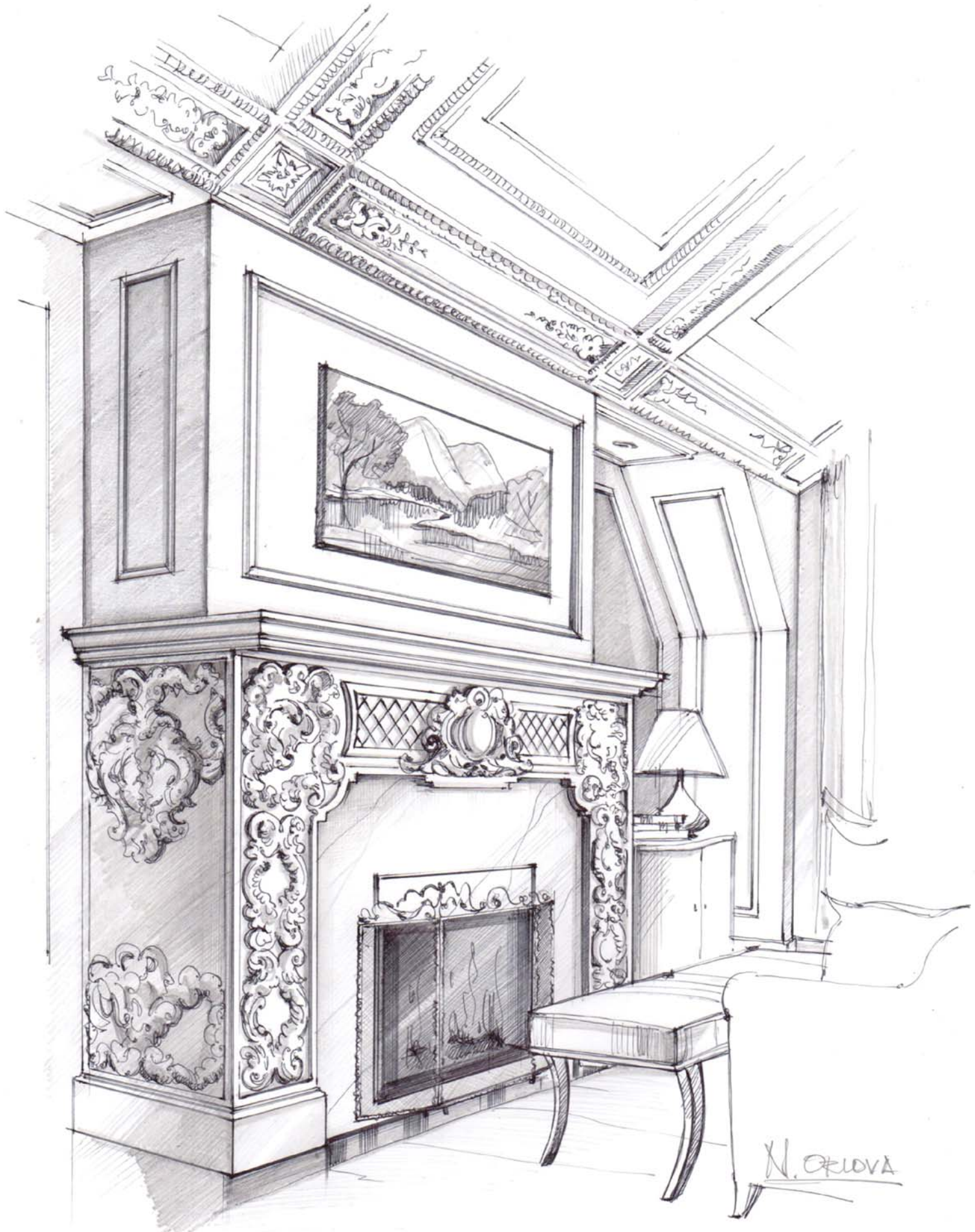



LORI MORRIS™

**CUSTOM DESIGN MANTEL**

SHOWN IN CUSTOM COLOUR



SHOWN IN PLASTER PAINT READY

1100

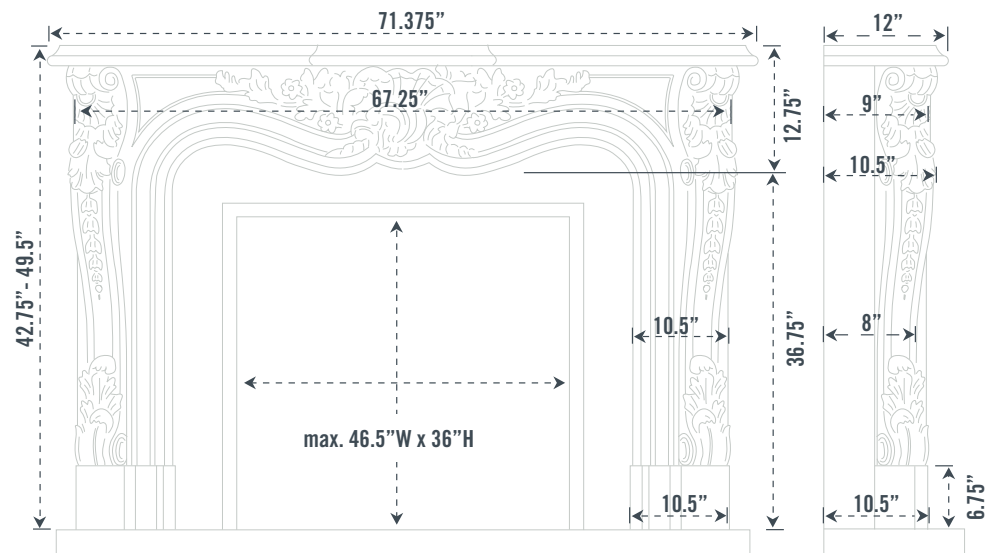



SHOWN IN CHOCOLATE BLACK VEINED HONED

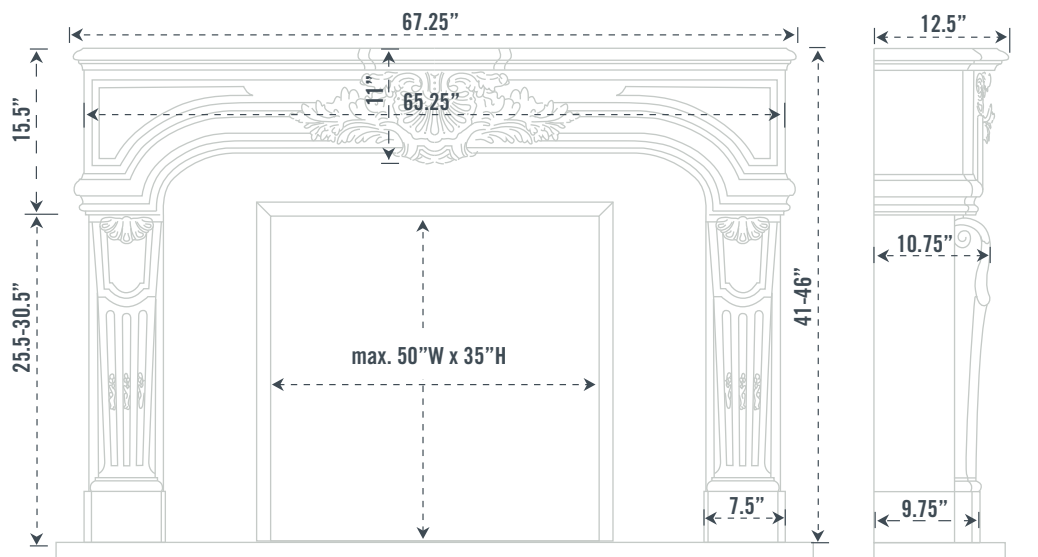

1107



SHOWN IN PEARL HONED

1101

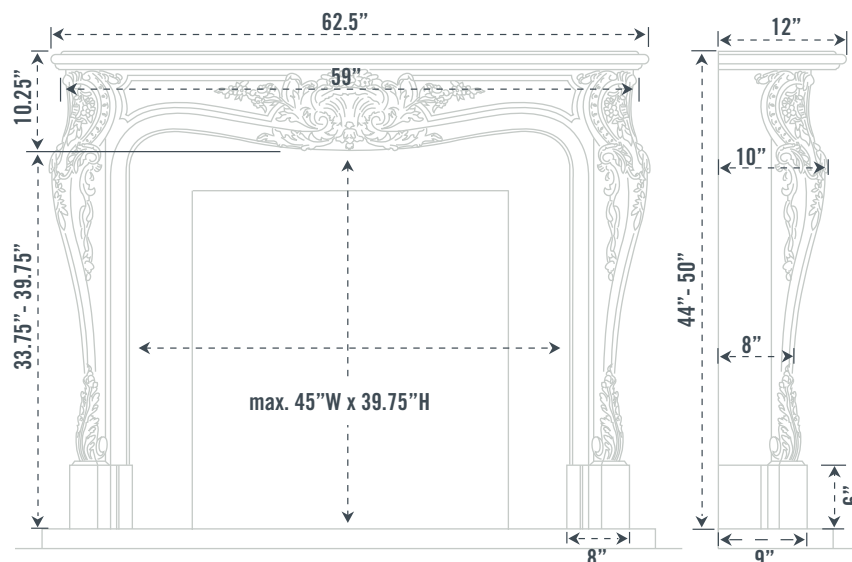





SHOWN IN SAHARA VEINED HONED

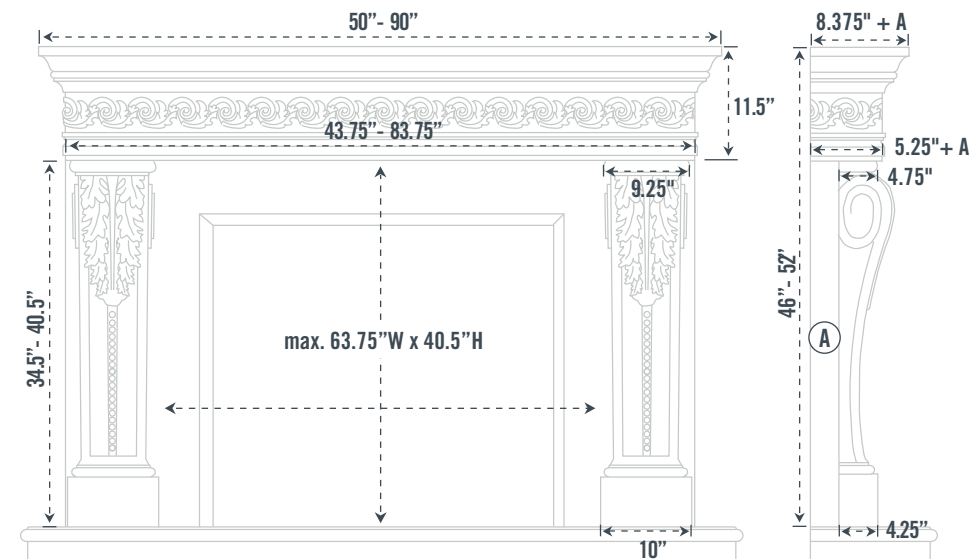

## 1110.SCROLL.529 CABINET



SHOWN IN SAHARA VEINED HONED

1145.534

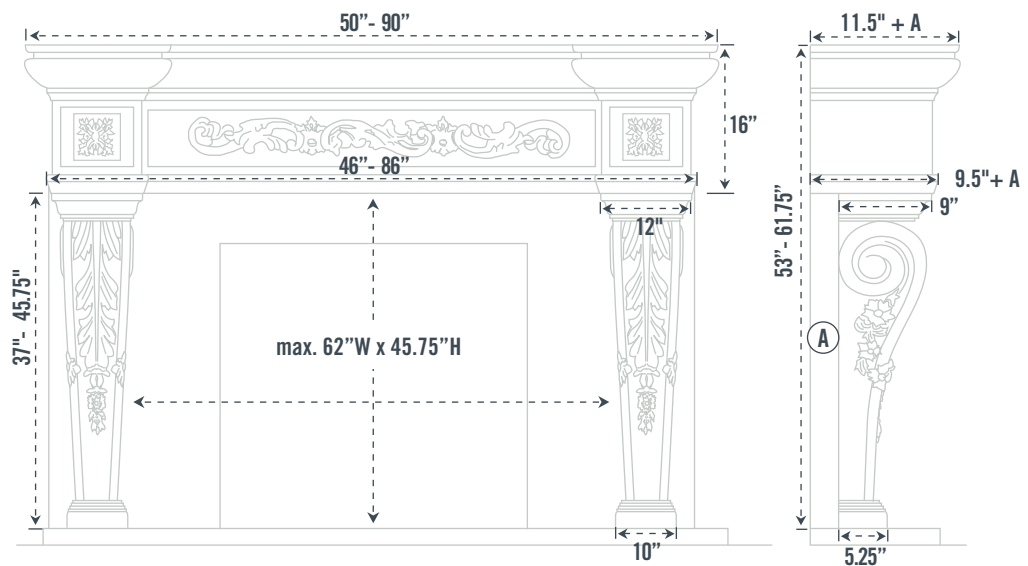



SHOWN IN TAUPE OPEN CAST

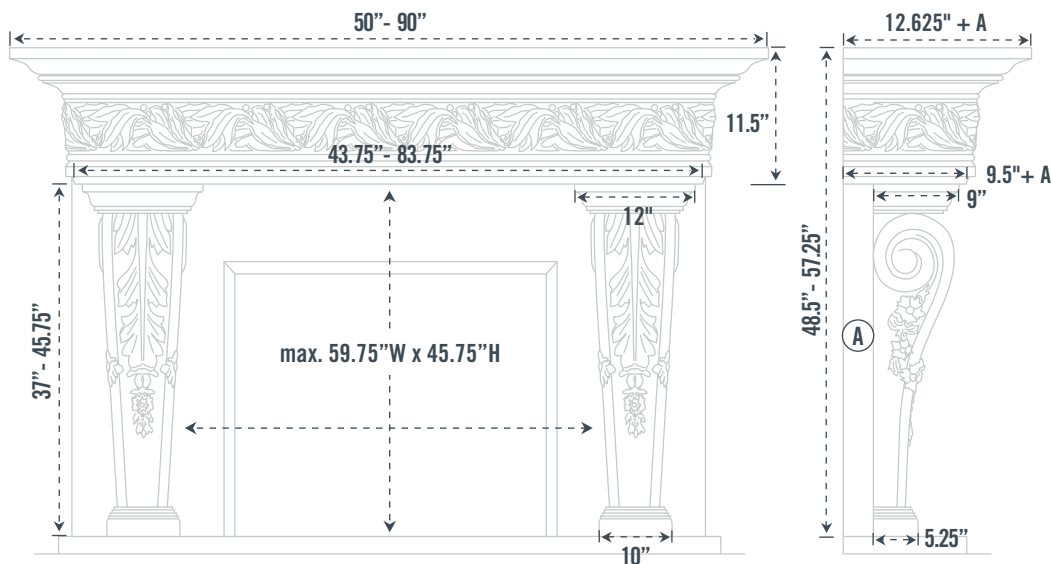

# 1110.LEAF.534



SHOWN IN BUFF OPEN CAST

# 1110.SHELL.557

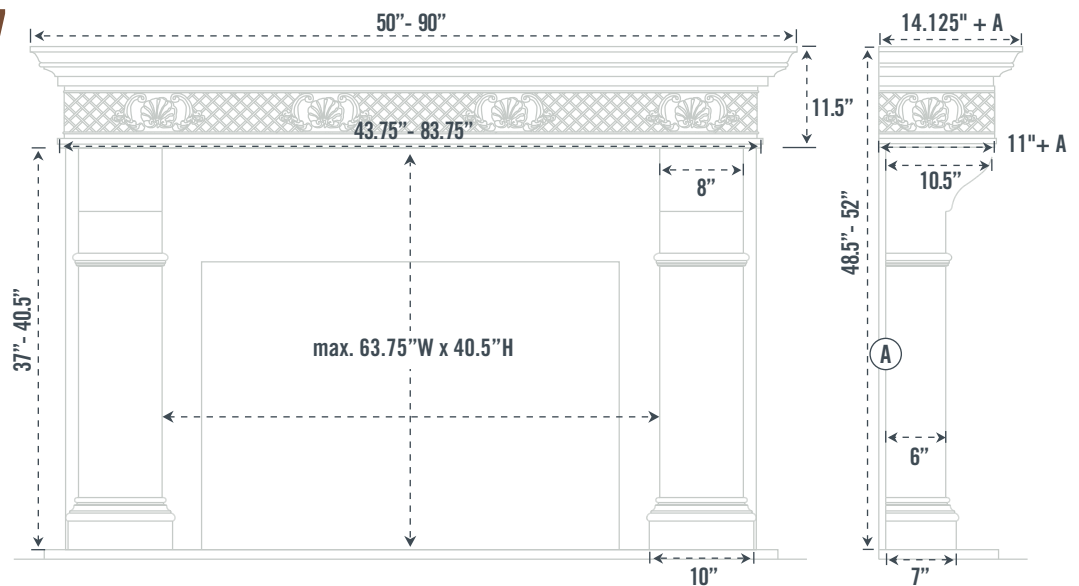



SHOWN IN LIMESTONE OPEN CAST

1127.577

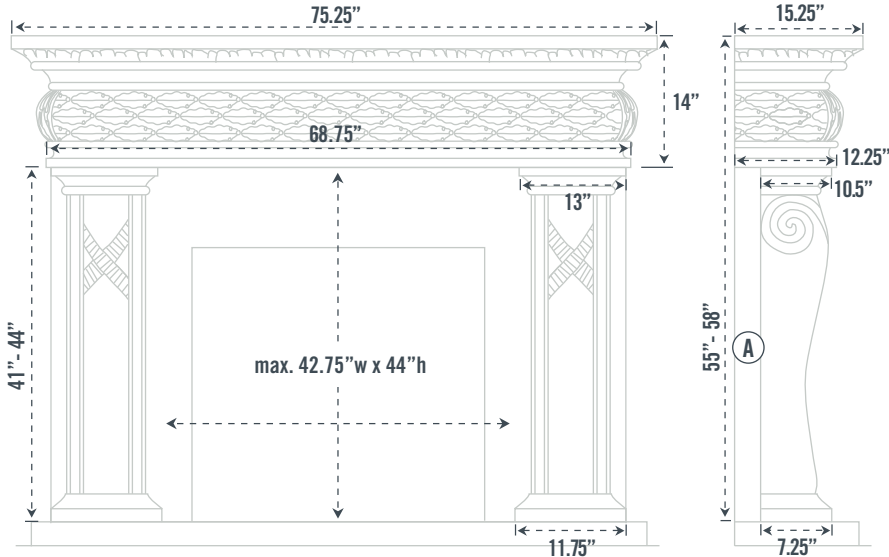



SHOWN IN SAHARA VEINED HONED

# 1141.524

WITH PLINTHS

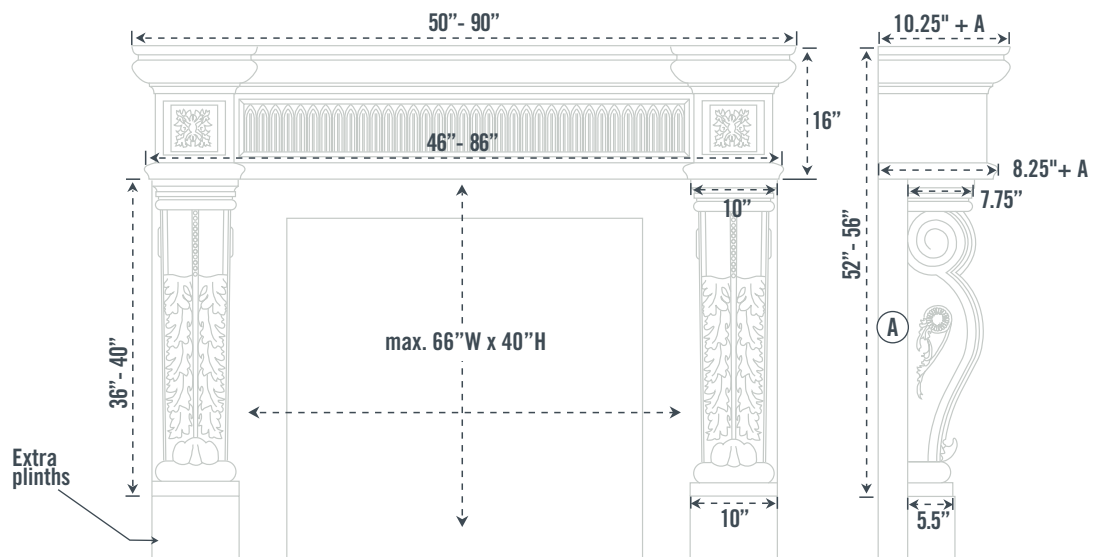



SHOWN IN LIMESTONE OPEN CAST

**1136.11.545**

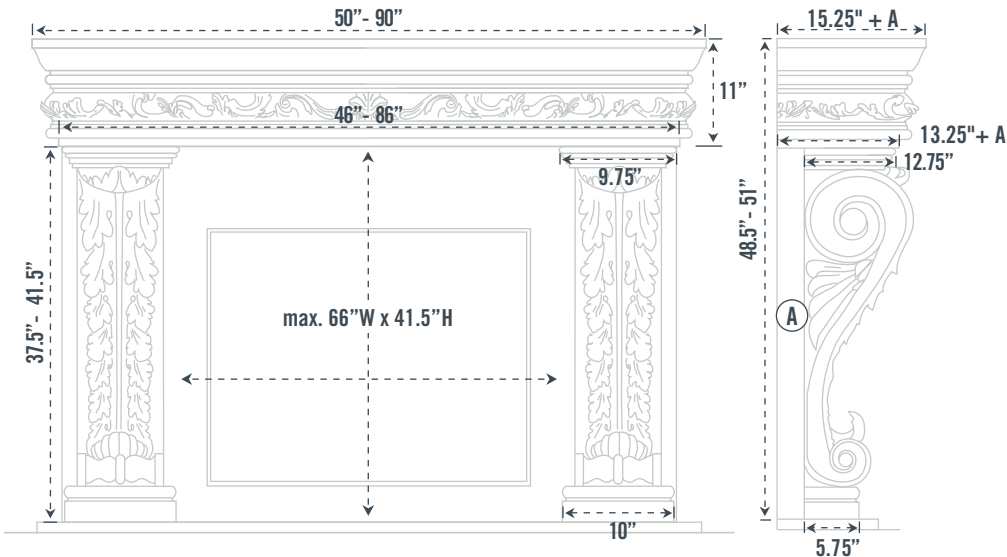



SHOWN IN SAHARA HONED

1112.533

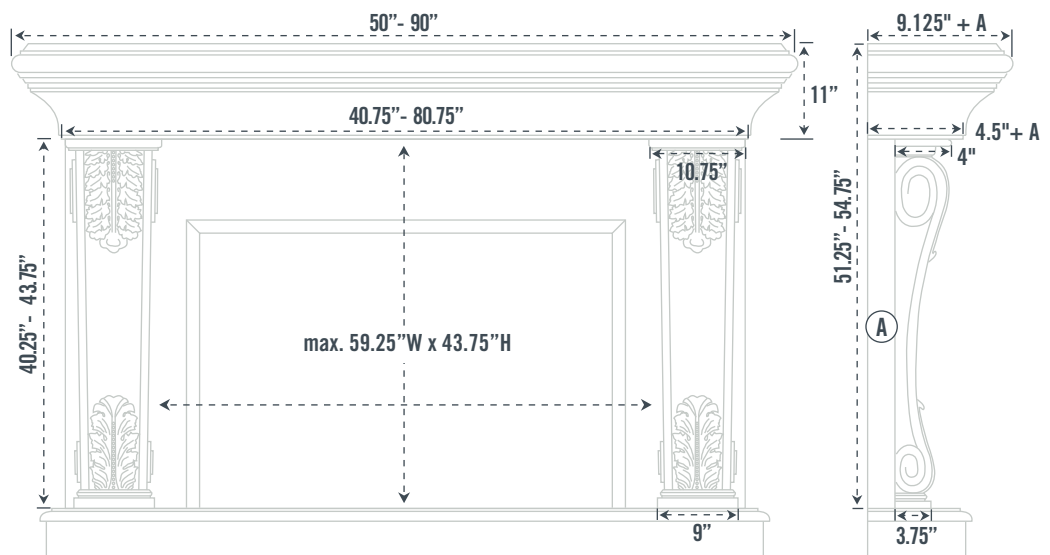





SHOWN IN SAHARA VEINED HONED

1152.546

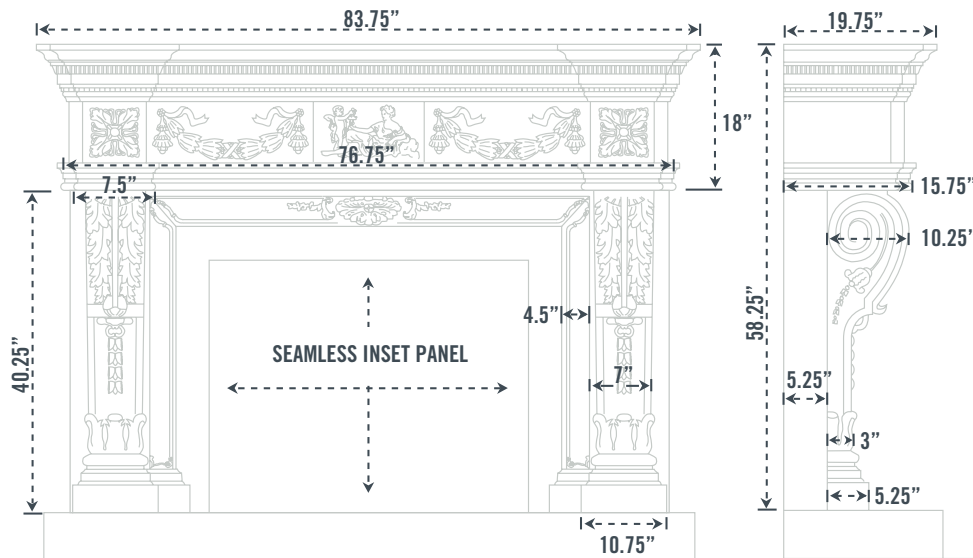



SHOWN IN TAUPE OPEN CAST

**1135.537**

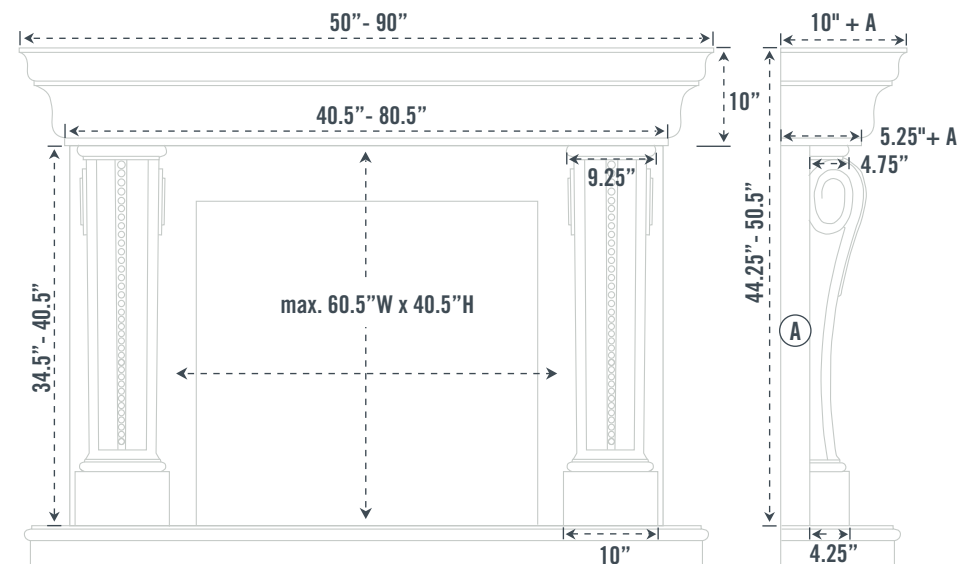

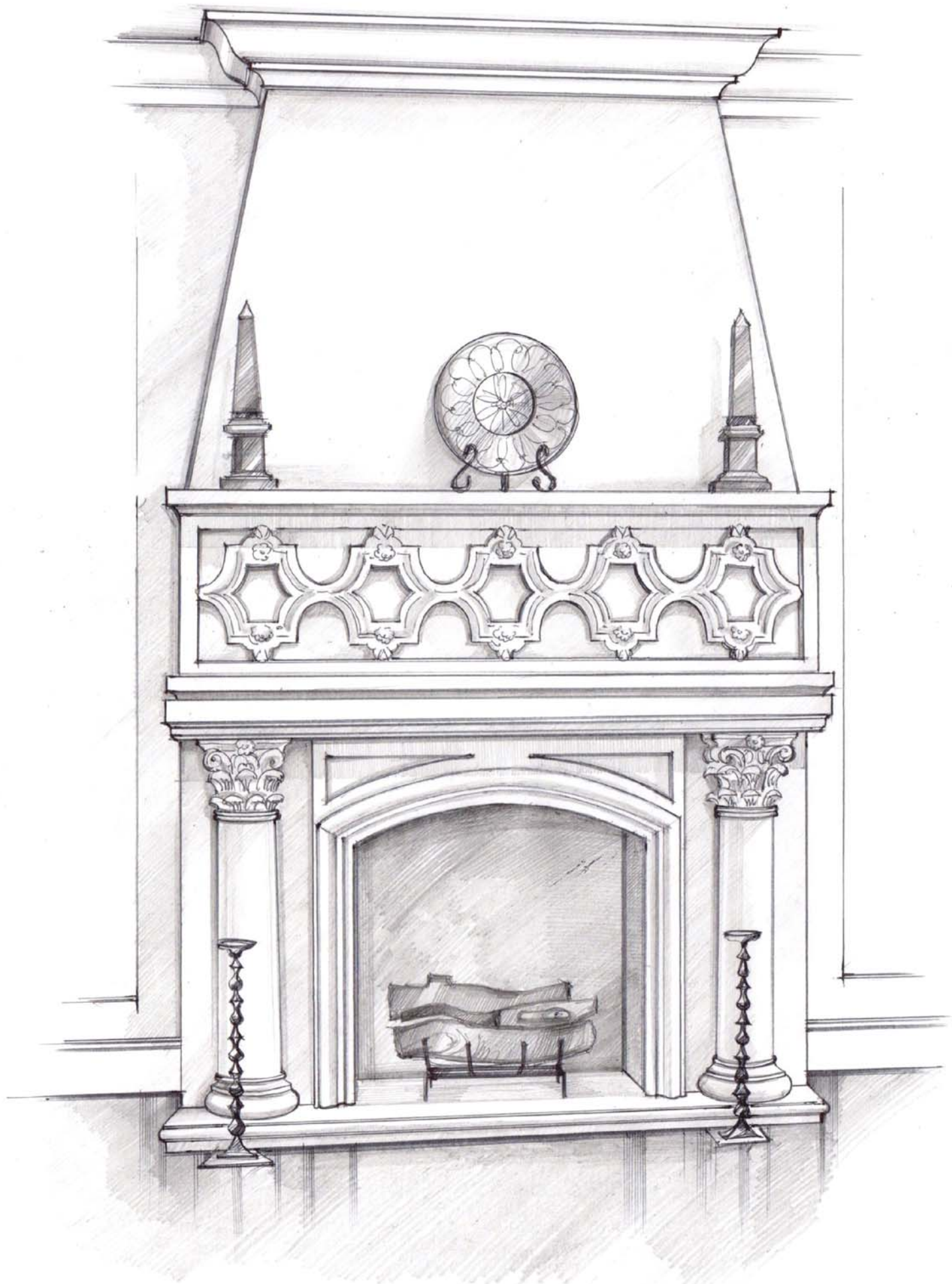

*N. GIOVA*



**1136.548**  
CUSTOM ROYAL OVERMANTEL

SHOWN IN SAHARA VEINED HONED

# 1142.524

## ROYAL OVERMANTEL

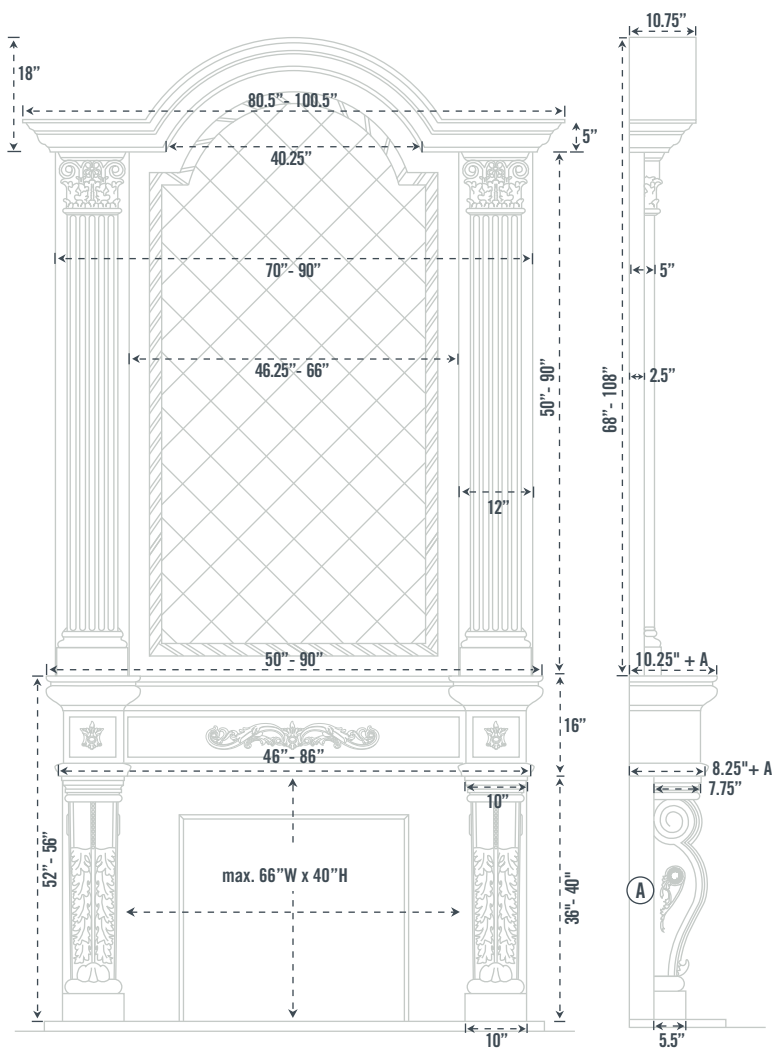

SHOWN IN BUFF OPEN CAST



**1144.533**  
CAPRI OVERMANTEL WITH RECESS

SHOWN IN SAHARA HONED

# 1136 CUSTOM.548 CABINET

INCL. #1109 SECONDARY SHELF  
CUSTOM REGAL OVERMANTEL

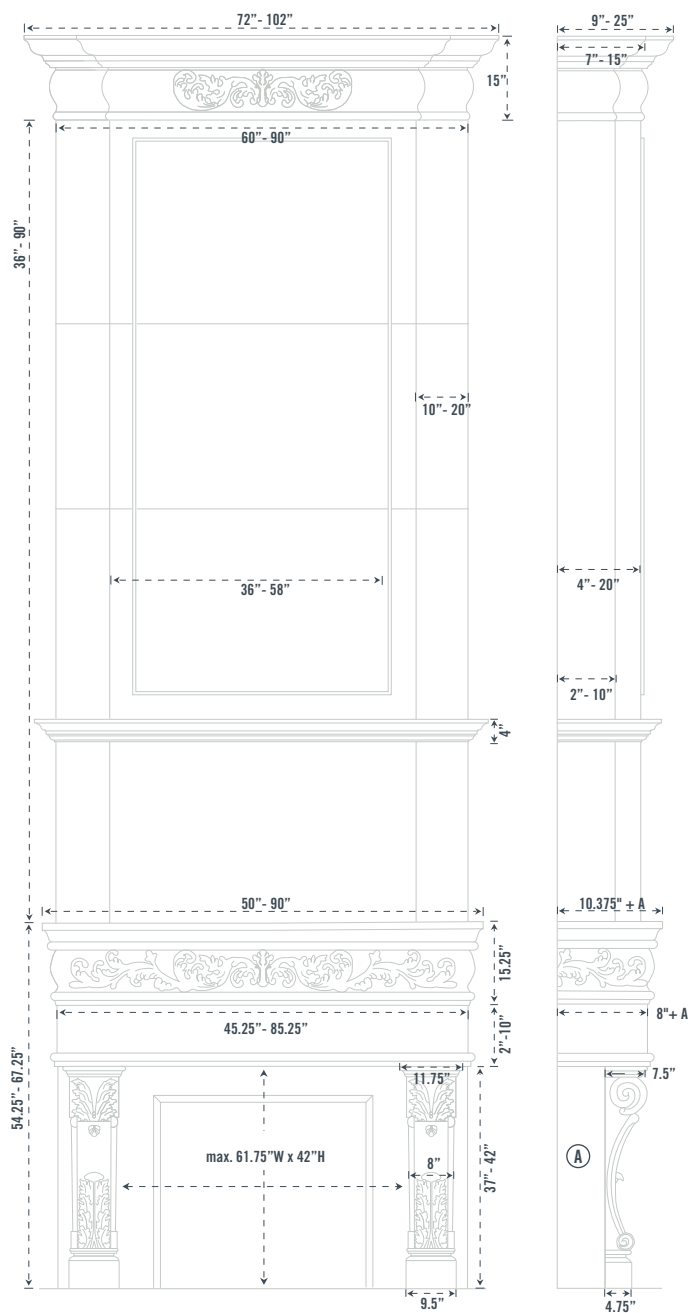

Panel sizes are customized to suit your requirements.



SHOWN IN SAHARA VEINED HONED

# 1136.548

## CUSTOM REGAL OVERMANTEL

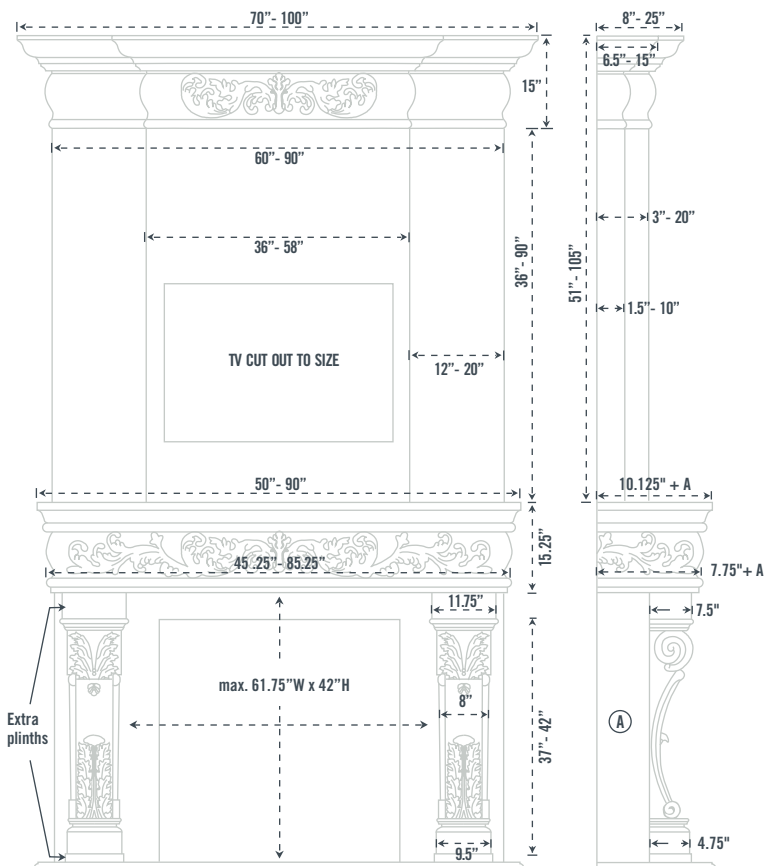

STEEL MILL ACCENTS



SHOWN IN SAHARA VEINED HONED WITH STEEL MILL ACCENTS





# 1108.536

## COLONIAL OVERMANTEL

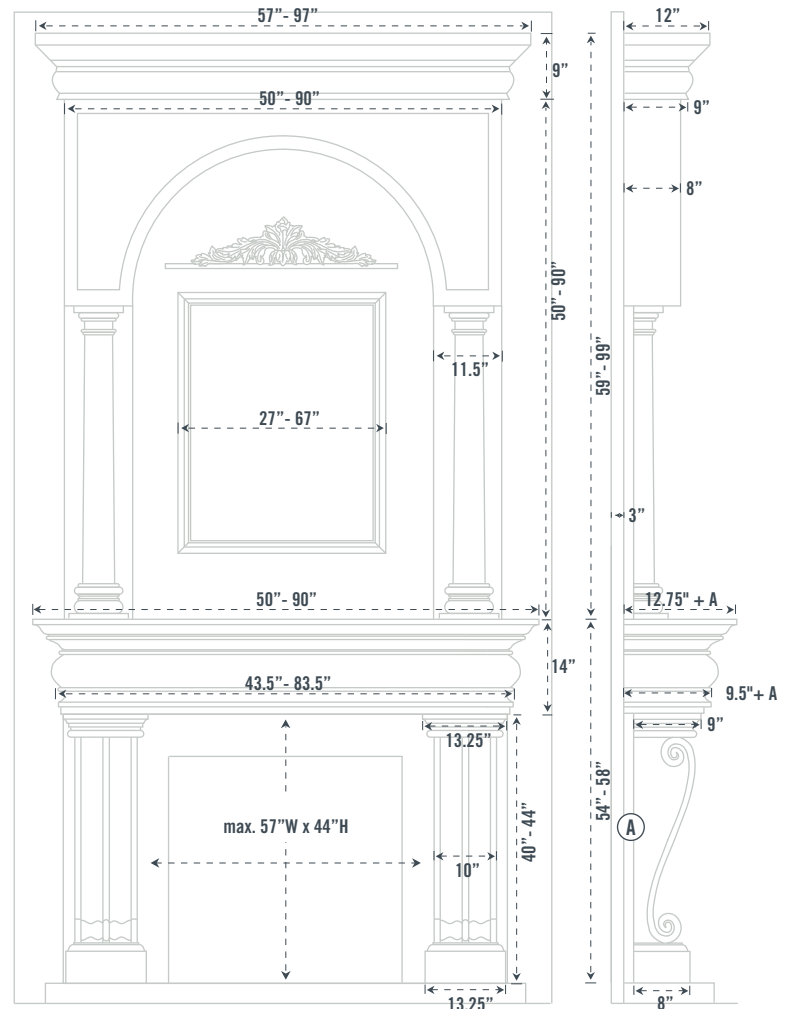

SHOWN IN SAHARA DIAMOND



**1145.534**  
ROYAL OVERMANTEL

SHOWN IN SAHARA VEINED HONED



**1106.SCROLL.536**  
CUSTOM TREVI OVERMANTEL

SHOWN IN ASH HONED



# 1136.548

## REGAL OVERMANTEL

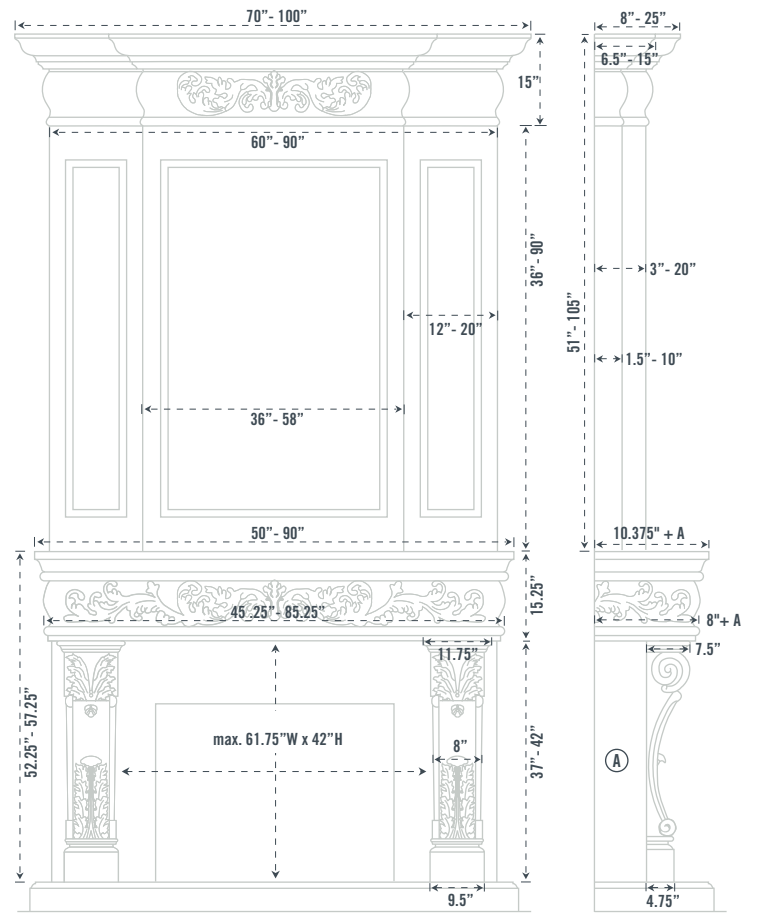

SHOWN IN SAHARA VEINED HONED



# 1160.540 CABINET

## VALENCIA OVERMANTEL

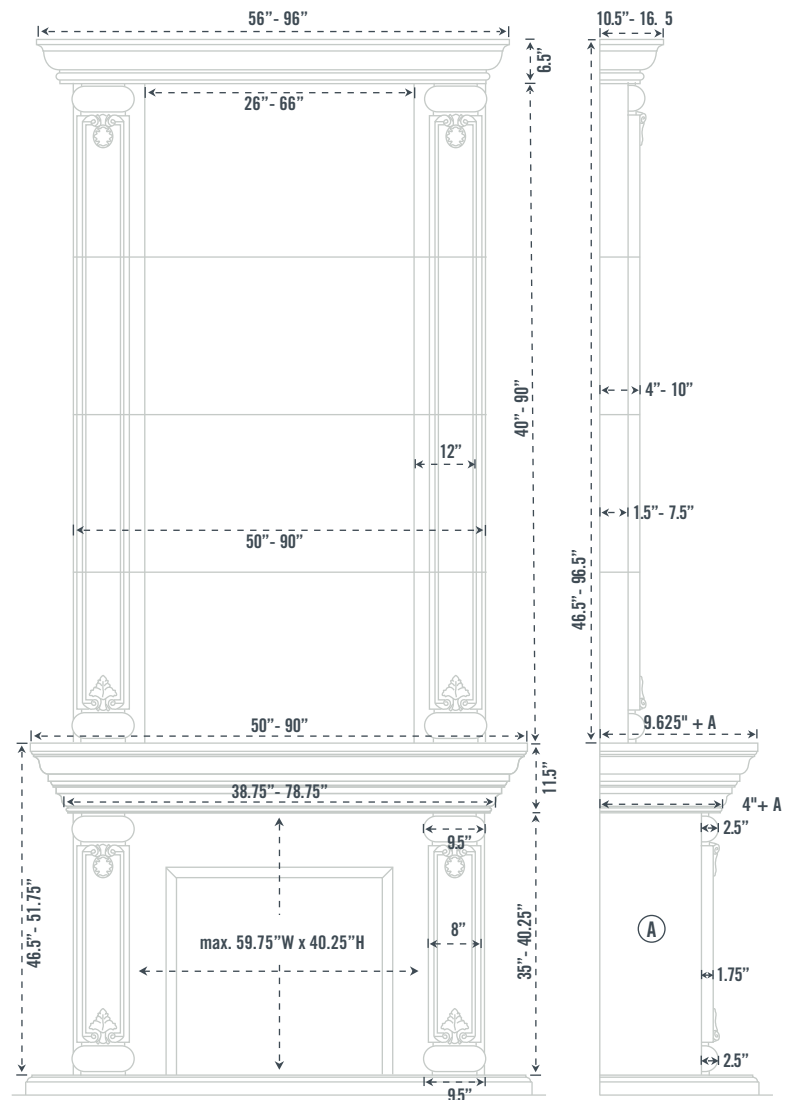

SHOWN IN CABINET STYLE IN TAUPE OPEN CAST



# 1136.555

## CALEDON OVERMANTEL

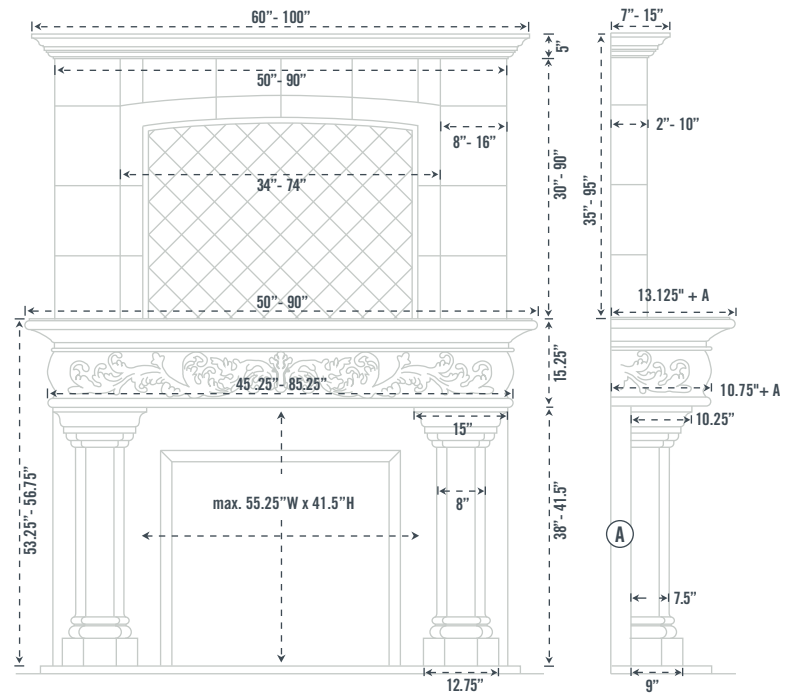

SHOWN IN NATURAL OPEN CAST



## 1136.524 CABINET

INCL. 1109 SECONDARY MANTEL AND CUSTOM REGAL OVERMANTEL

SHOWN IN SAHARA VEINED HONED



SHOWN IN SAHARA HONED

# 1106.536

## MONACO OVERMANTEL

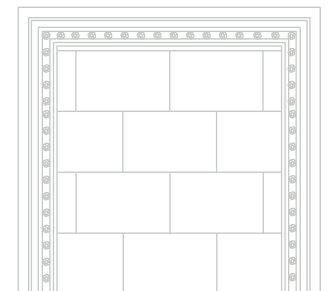
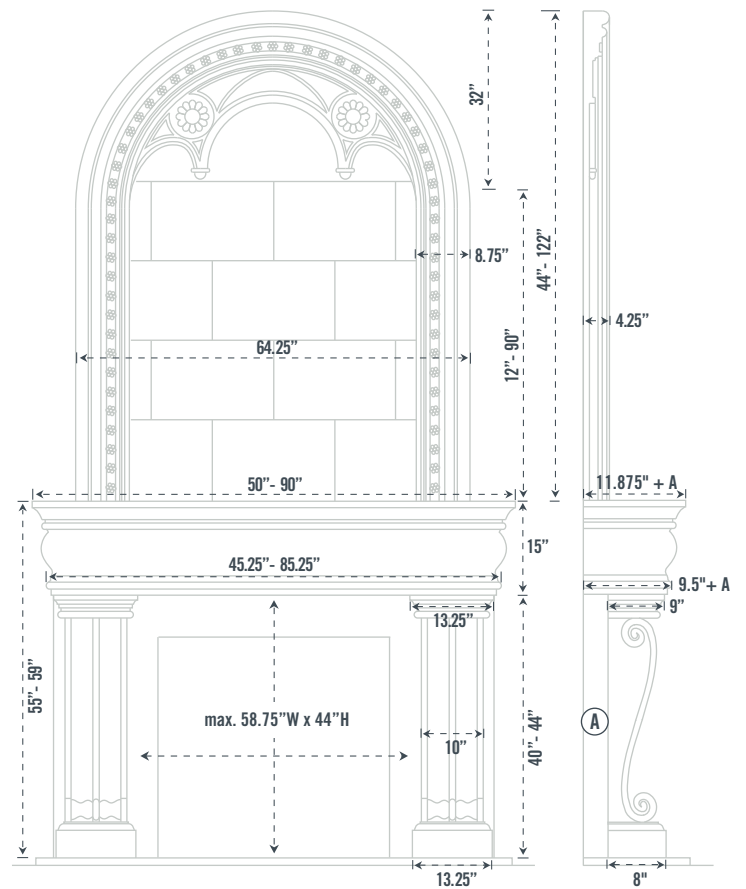

Monaco Overmantel is available in a square finish.



# 1108.536

## AZZURO OVERMANTEL

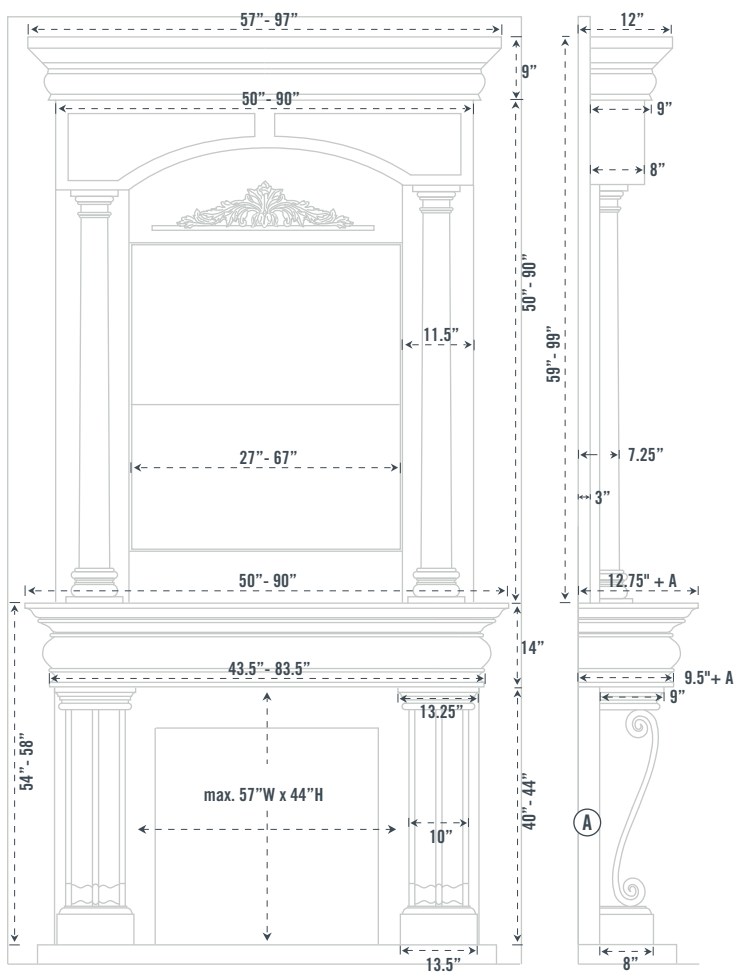

SHOWN IN OLIVE HONED WITH DARK GRAY HONED CENTER PANELS

*Transitional/Contemporary Series*

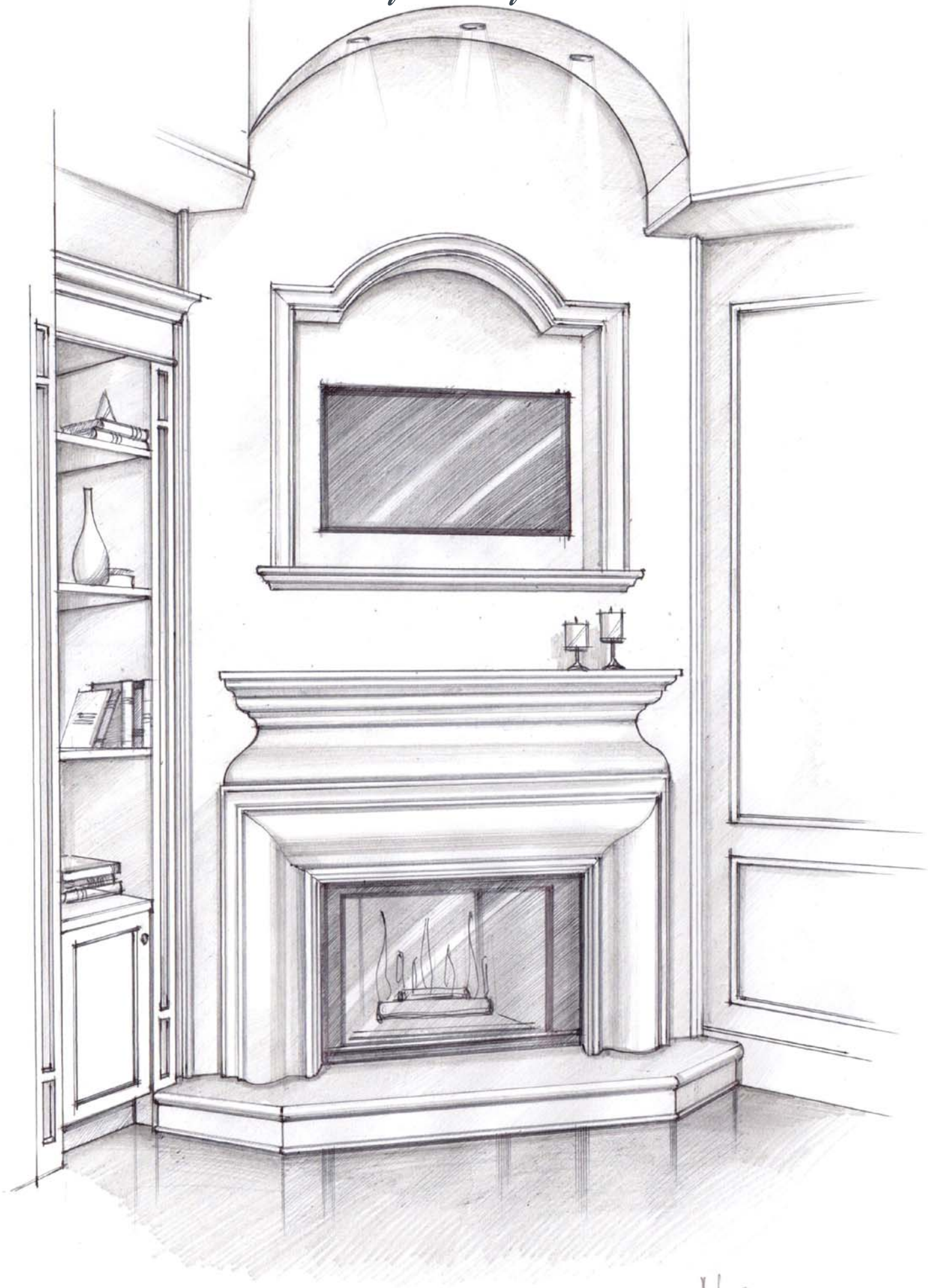

*N. GIOVA*



1120

SHOWN IN CUSTOM BLACK HONED



**CUSTOM SLABS**

SHOWN IN GRAY OPEN CAST



**CUSTOM**

SHOWN IN NATURAL OPEN CAST



SHOWN IN PEARL HONED

# 1113

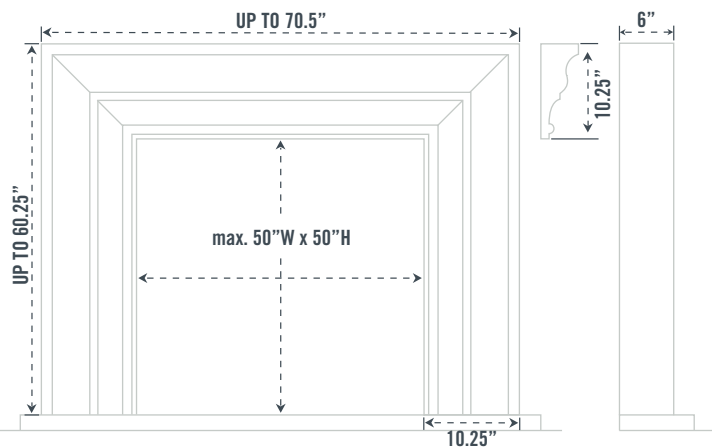

# 1113 & 1110 CROWN

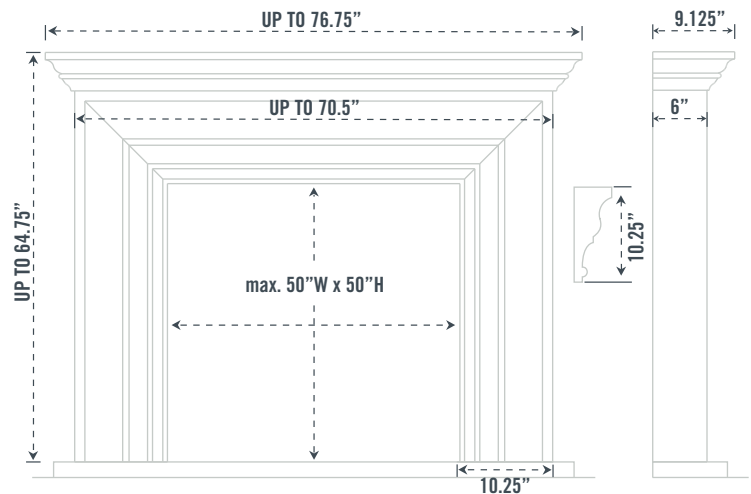



**1113 & 1110 CROWN**

SHOWN IN ASH HONED



SHOWN IN SAHARA HONED

# 1116

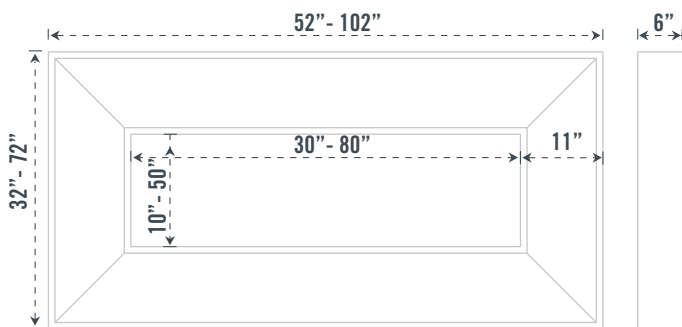

1116 (Profile 11")

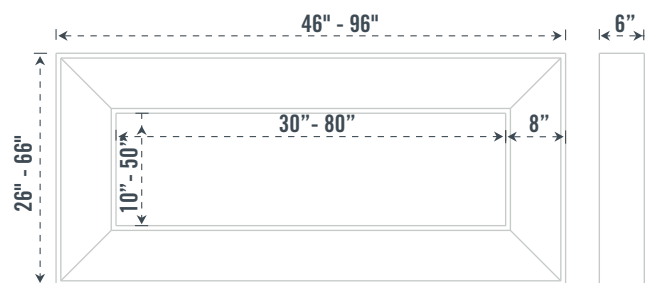

1116 (Profile 8")





SHOWN IN OLIVE HONED

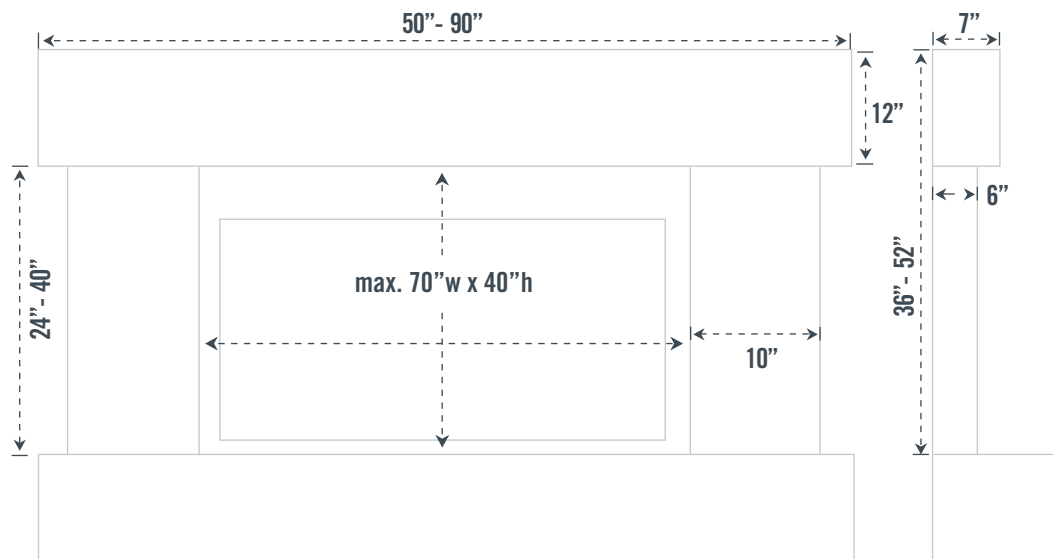

**7701**



SHOWN IN GRAY HONED

**1115.11**

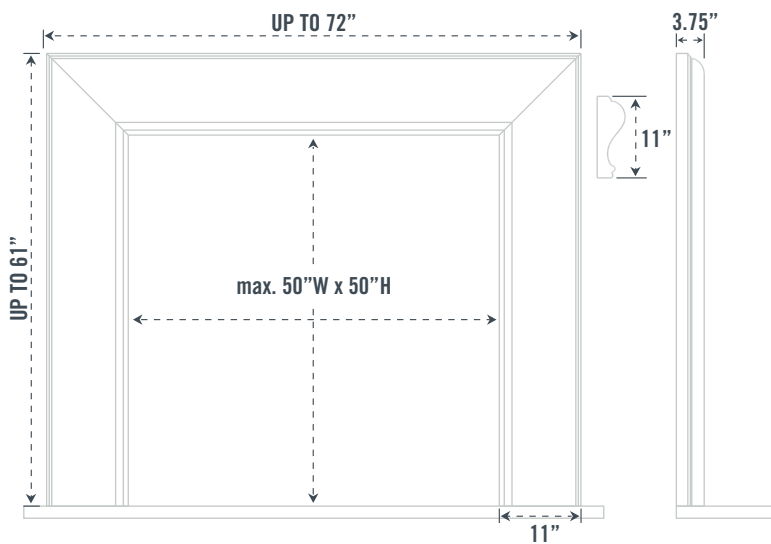

**1115.7**

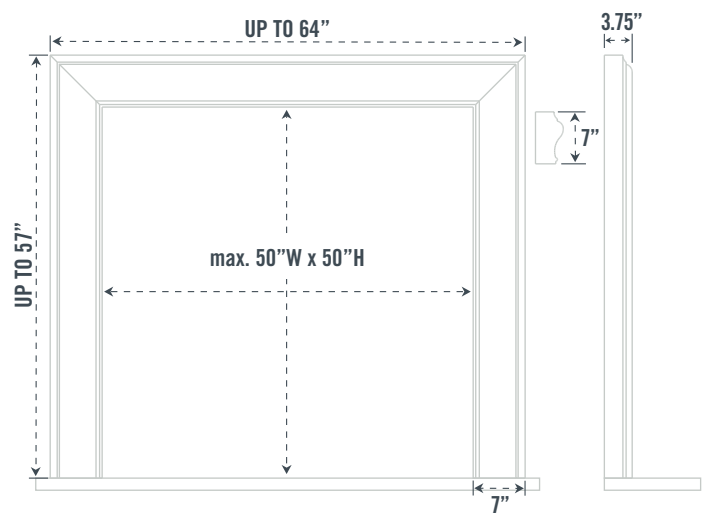



SHOWN IN CUSTOM GRAY HONED

**7702**

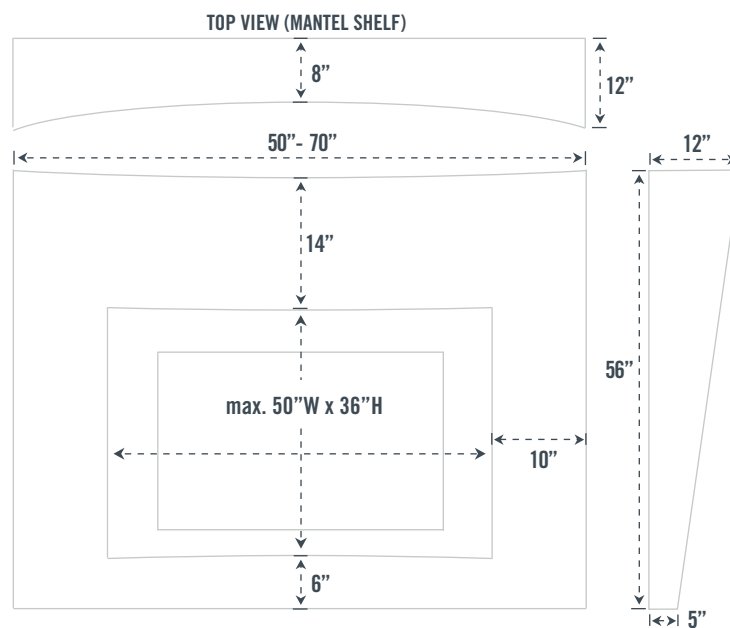



SHOWN IN CUSTOM GRAY OPEN CAST

**7703**

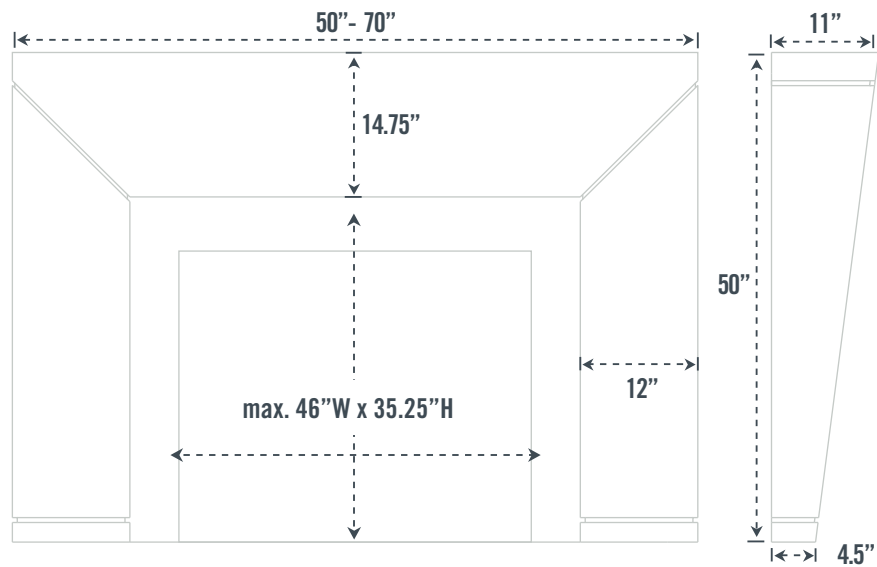



SHOWN IN NATURAL OPEN CAST

## 1114S

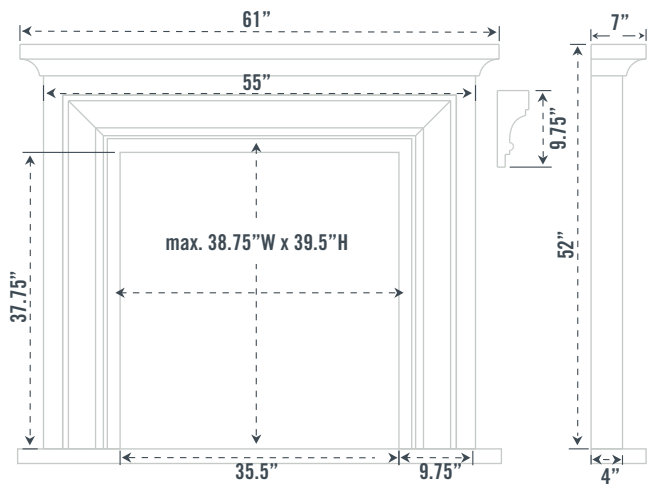

## 1114L

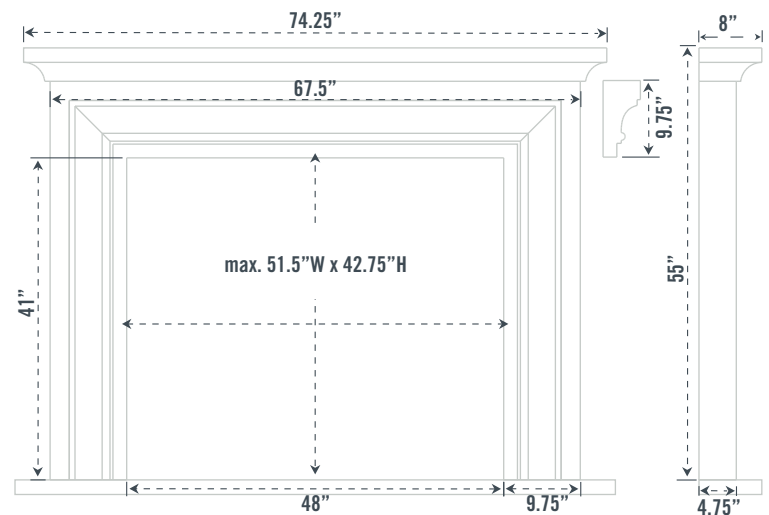



SHOWN IN CHOCOLATE HONED

# ATLANTA

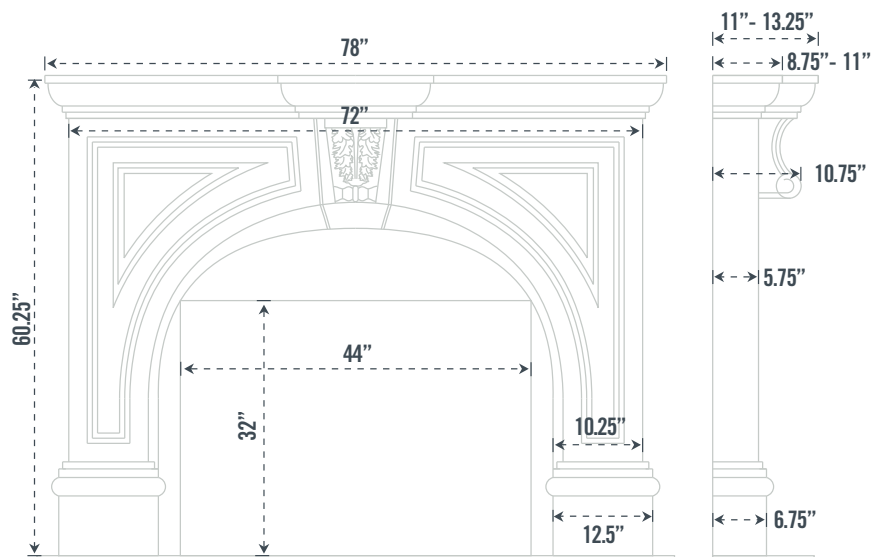

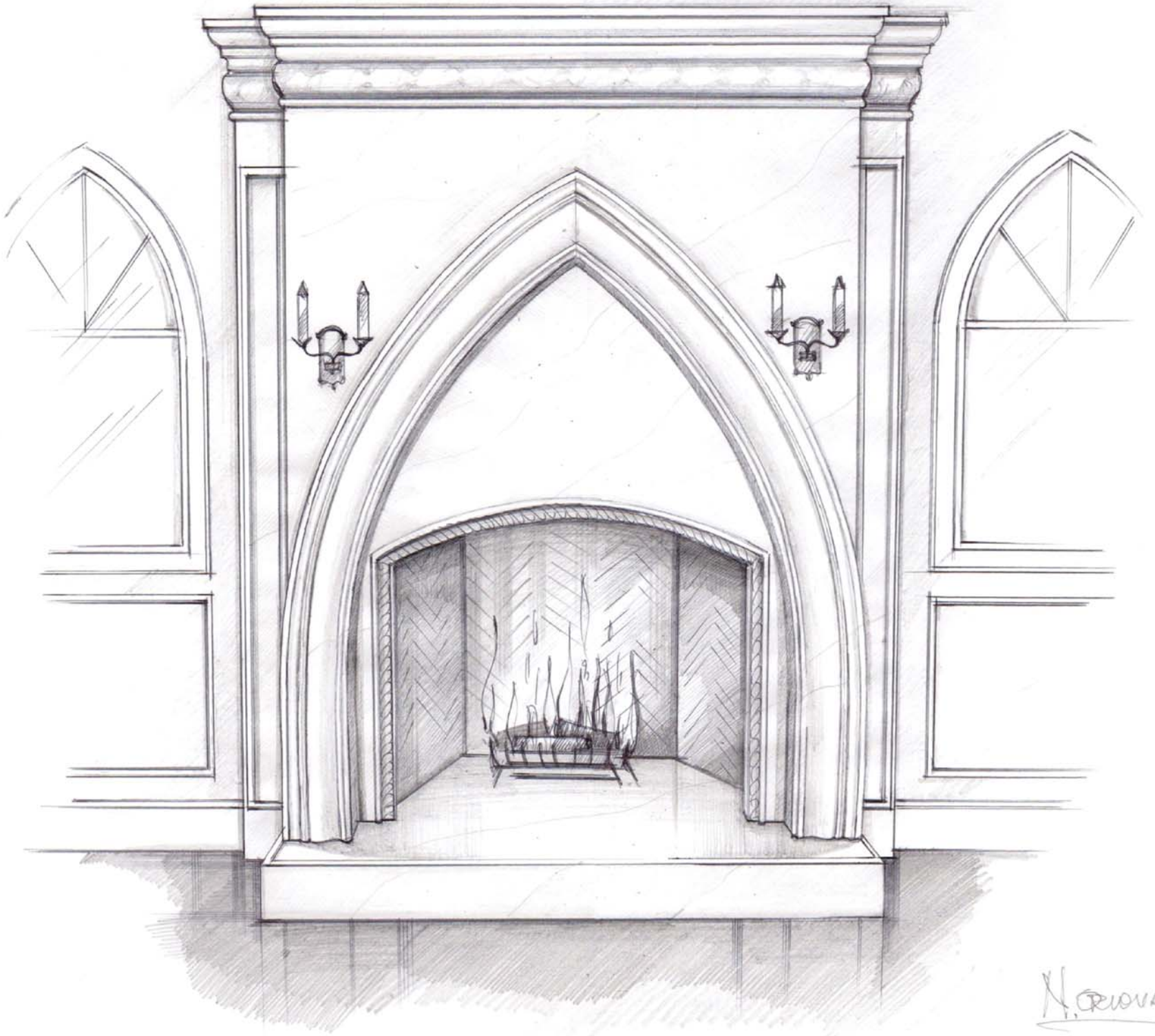

N. ORIOVA



**1115.11** INCL. 1110 CROWN  
 CAPRI OVERMANTEL  
 INCL. TV NICHE & TRIM

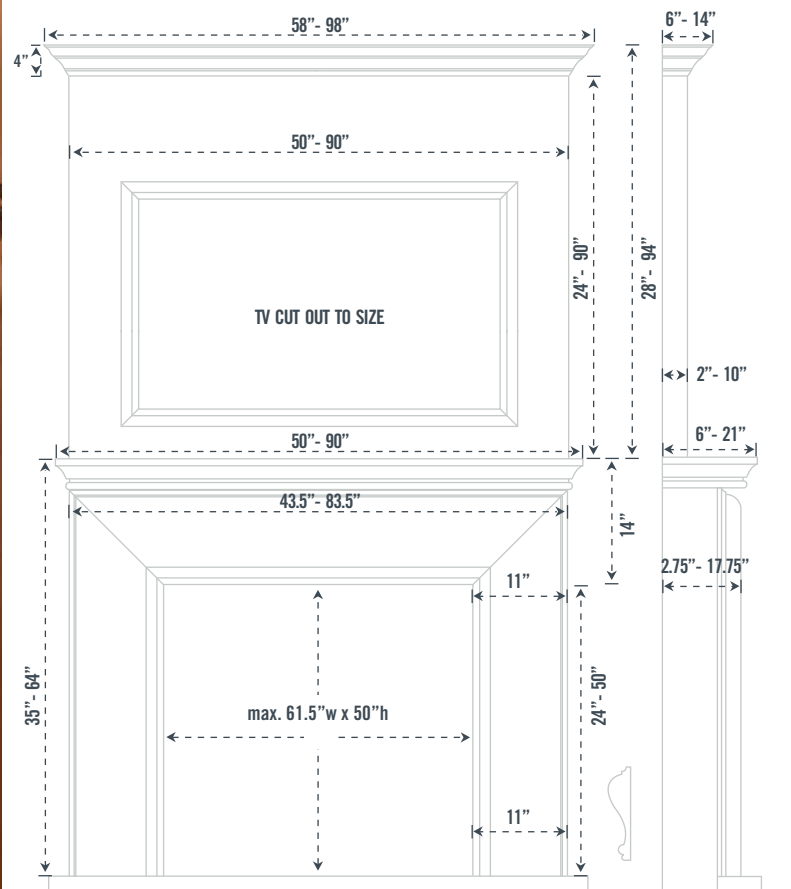

SHOWN IN CHOCOLATE HONED





**1119**  
DAKOTA OVERMANTEL

SHOWN IN PEARL HONED



**1121**  
MADISON OVERMANTEL

SHOWN IN PEARL VEINED HONED



CUSTOM REGAL MANTEL/OVERMANTEL  
INCL. 1110 CROWN SHELF & TV NICHE

SHOWN IN SAHARA HONED



**1113 INCL. 1110 CROWN**  
**CAPRI OVERMANTEL INCL. RECESS**

SHOWN IN ASH HONED

# 7704

## SOHO OVERMANTEL

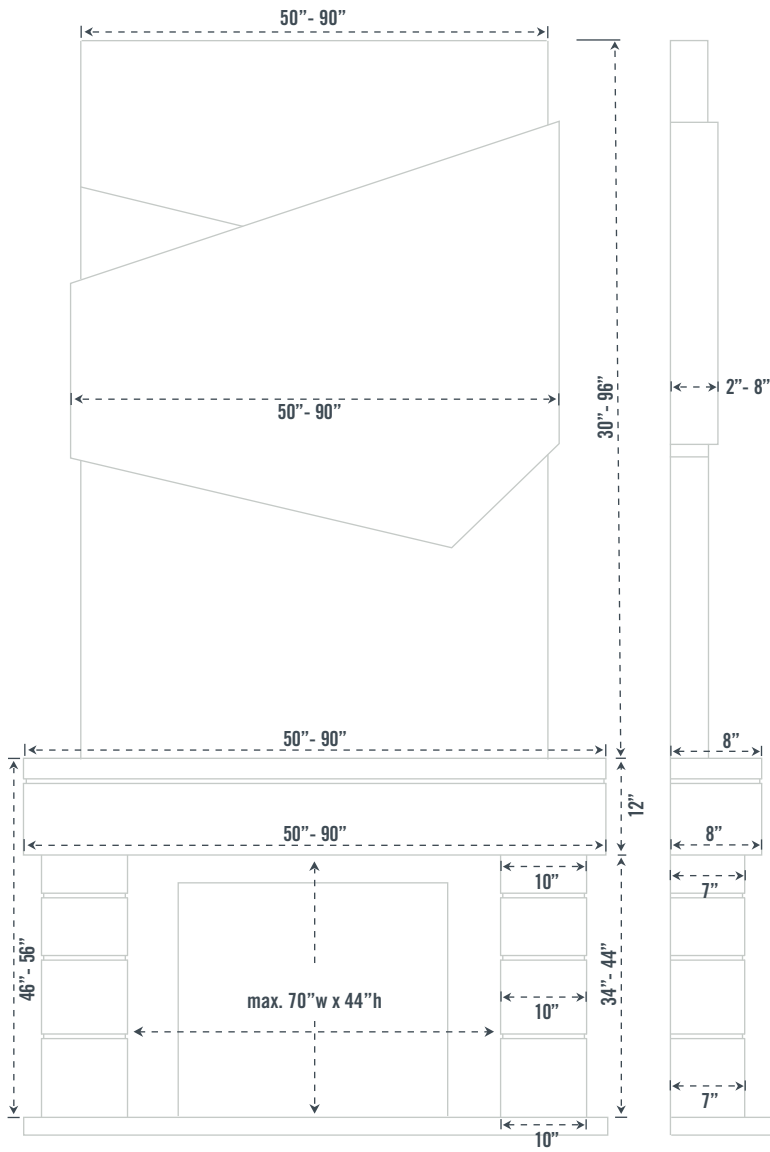

SHOWN IN GRAY HONED

# Slabs/Stacked Stone Series

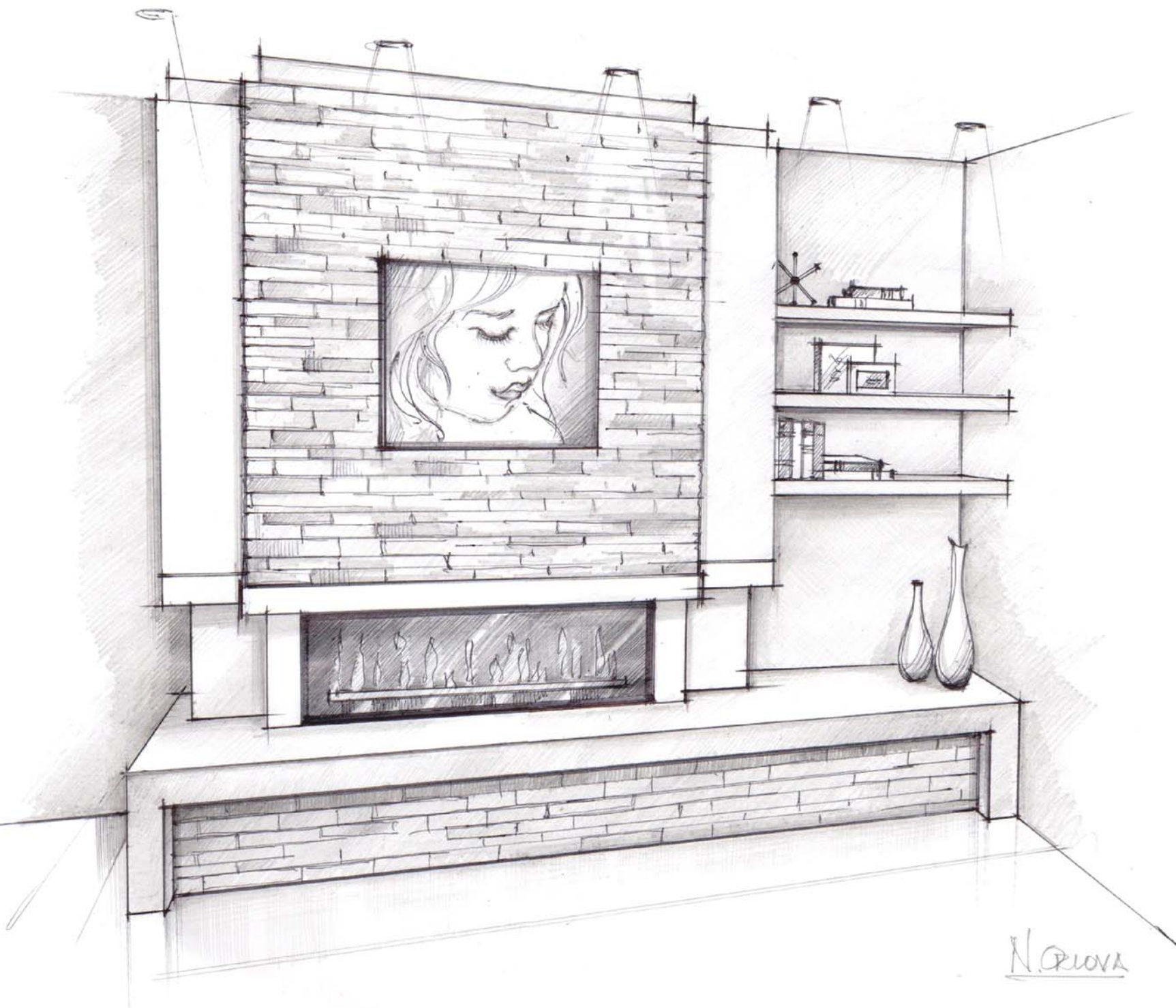



**STACKED STONE SLABS**

SHOWN IN LIMESTONE OPEN CAST



## STACKED STONE SLABS

SHOWN IN CUSTOM "TIM HORTONS" COLOUR HONED





**1122**  
CUSTOM SLAB WALL

SHOWN IN LIMESTONE OPEN CAST



## STACKED STONE SLABS

SHOWN IN SAHARA DIAMOND



## STACKED STONE SLABS

SHOWN IN SAHARA DIAMOND



## STACKED STONE SLABS

SHOWN IN NATURAL OPEN CAST



## STACKED STONE SLABS

SHOWN IN GRAY DIAMOND



## STACKED STONE SLABS

SHOWN IN SLATE GRAY HONED



**1116 & STONE TILES**

SHOWN IN LIMESTONE OPEN CAST

# GRANDSTOCK SERIES

Mantels that make a definitive statement of style, the Grandstock Series, Omega's Signature line, is a collection of distinctive, sophisticated styles that will provide an impressive focal point to any room.

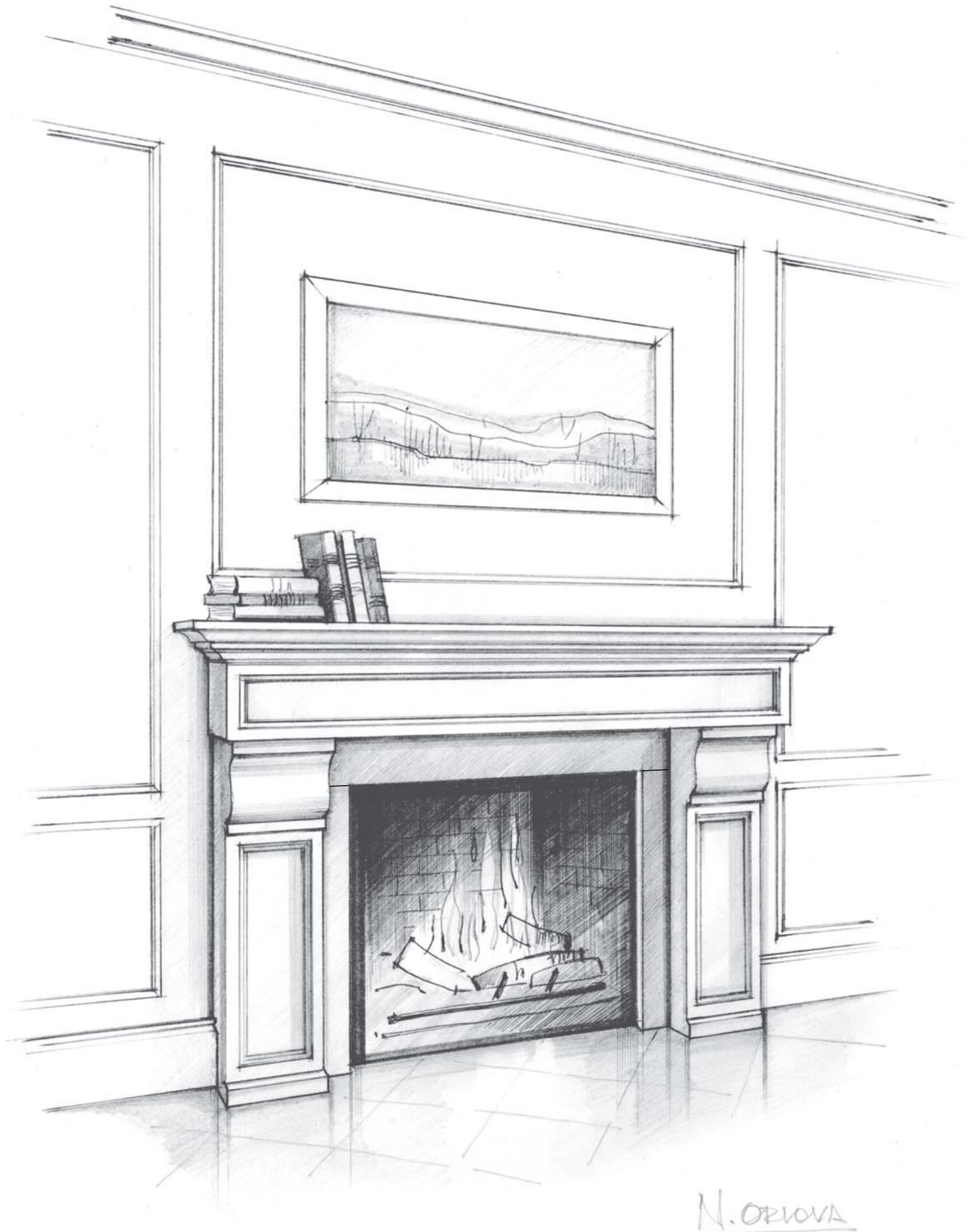





1106.536

SHOWN IN CHOCOLATE HONED

# 1106.556-GS

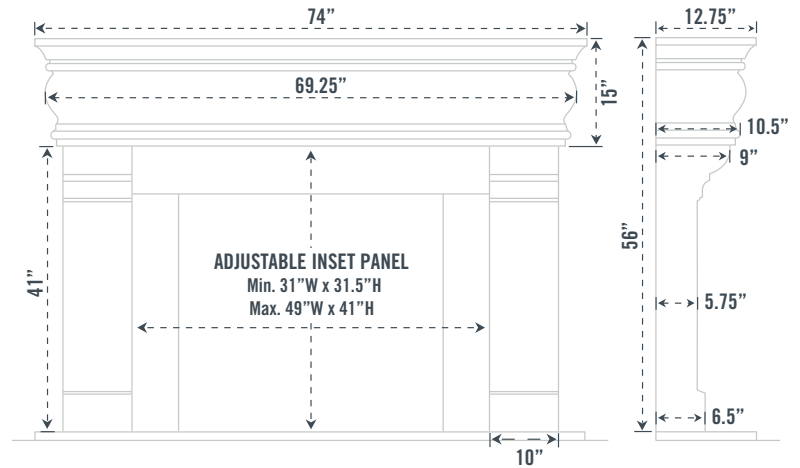

Recreating old world  
charm infused with  
distinctive modern  
day simplicity



1106.536-GS SHOWN IN LIMESTONE

# 1106.511-GS

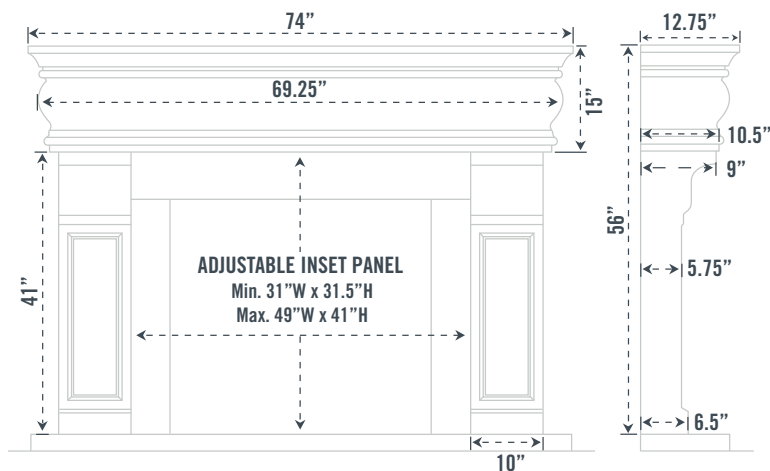

# 1106.536-GS

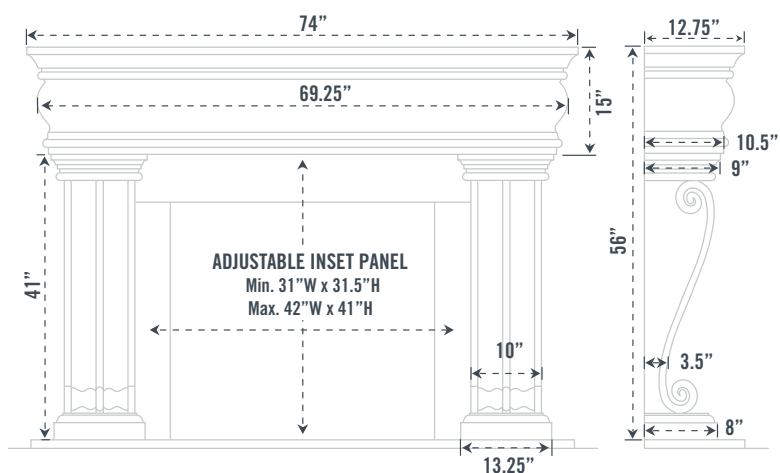

# 1106.555-GS

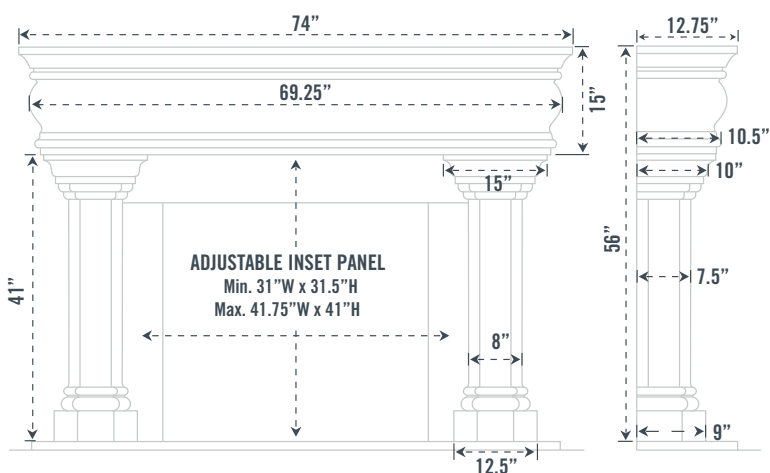

# 1110.556-GS

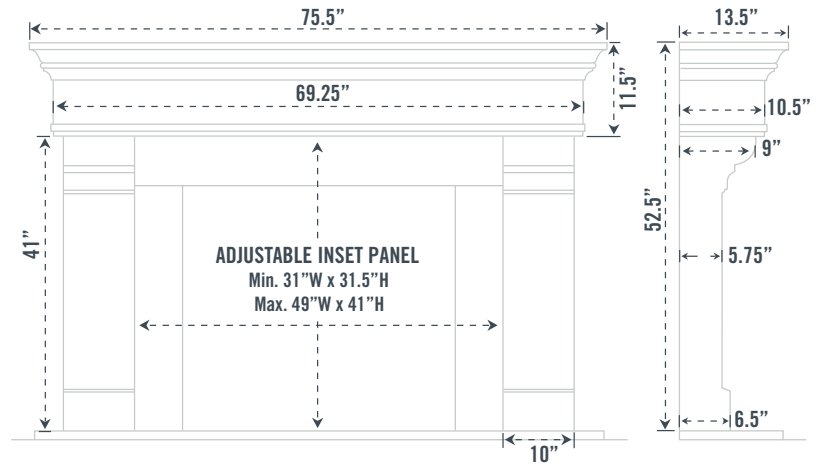

Adding elegance and  
warmth to any home with  
simplistic, clean details



1110.556-GS SHOWN IN NATURAL

# 1110.511-GS

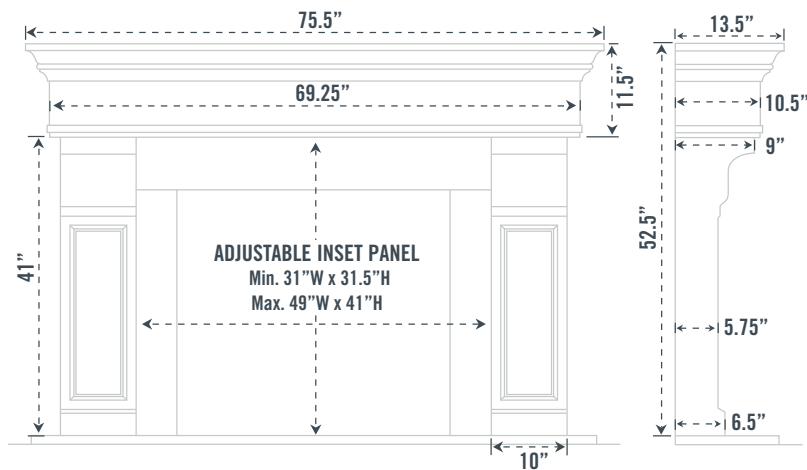

# 1110.536-GS

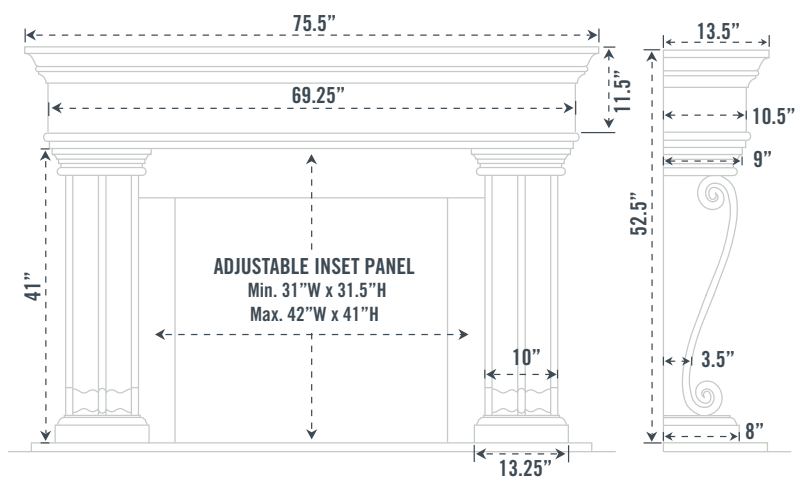

# 1110.555-GS

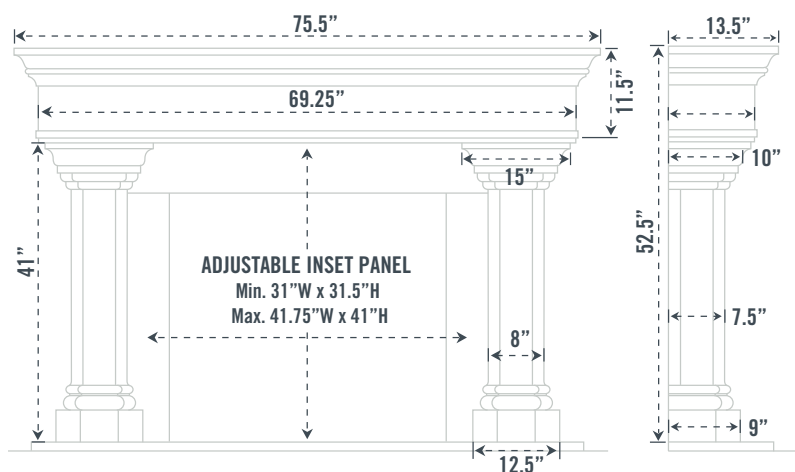

# 1110S.556-GS

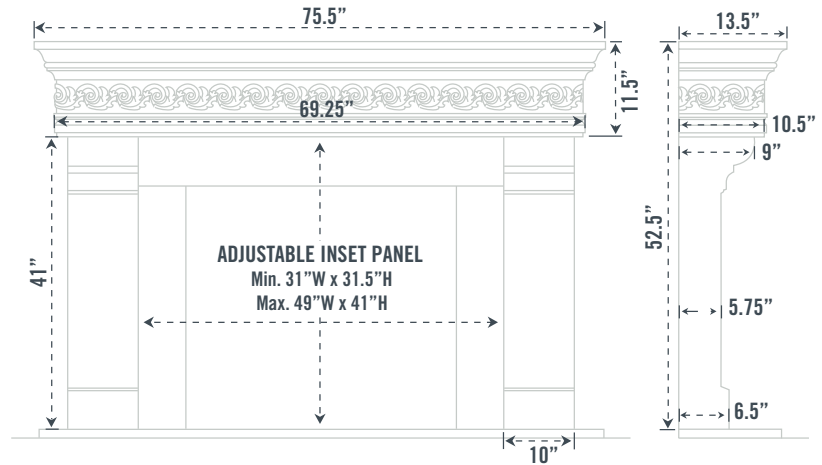

Redefining the ordinary with this delicate, handcrafted decorative mantel



1110S.556-GS SHOWN IN NATURAL

# 1110S.511-GS

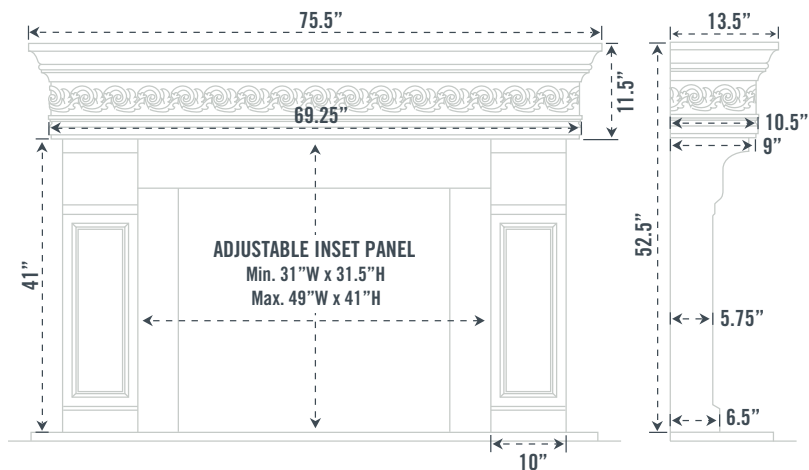

# 1110S.536-GS

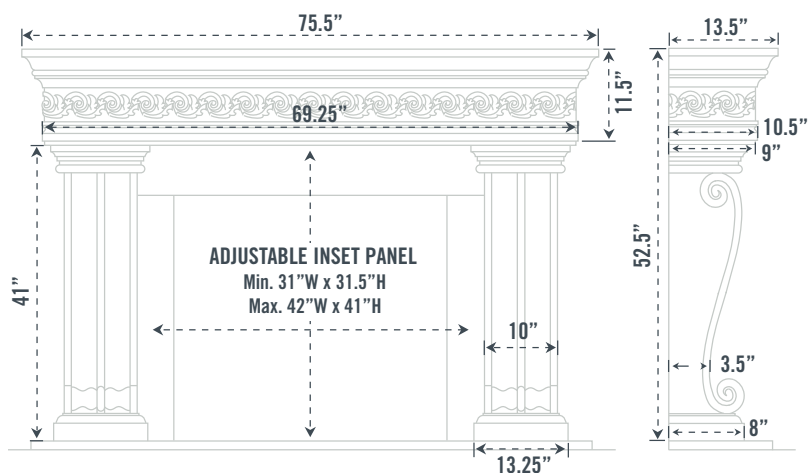

# 1110S.555-GS

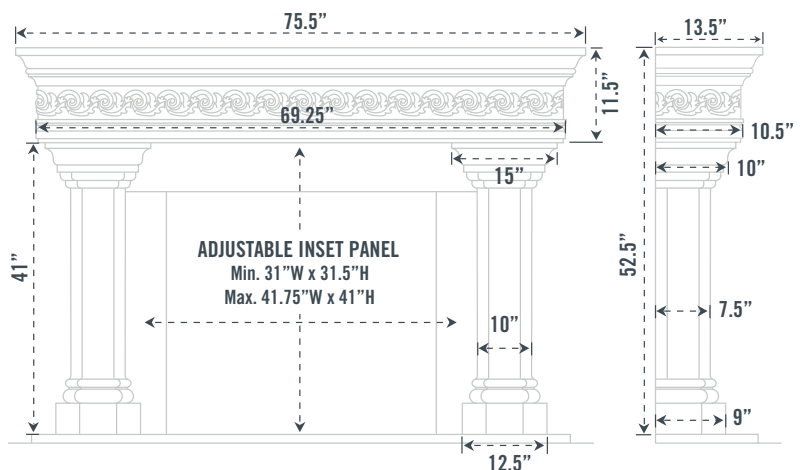

# 1111.556-GS

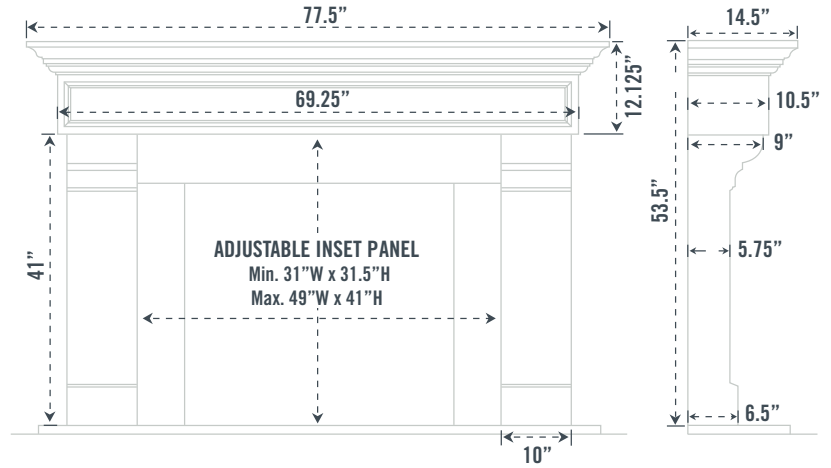

Simple in design, a  
modern interpretation  
of a classic piece



1111.511-GS SHOWN IN NATURAL



# 1111.511-GS

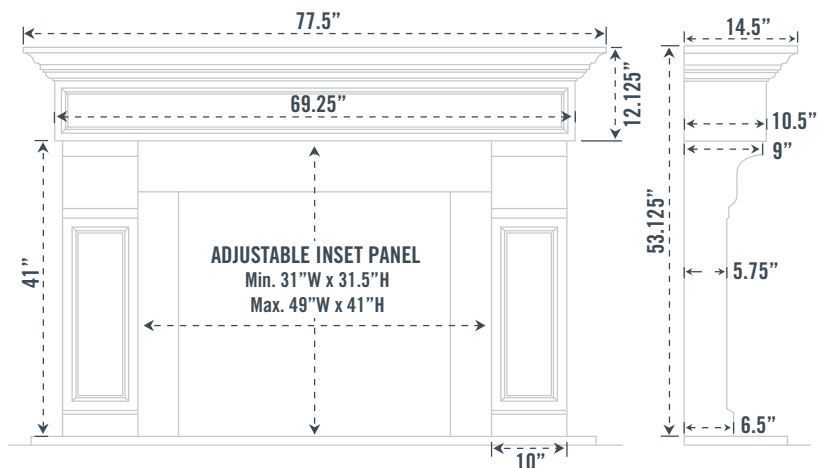

# 1111.536-GS

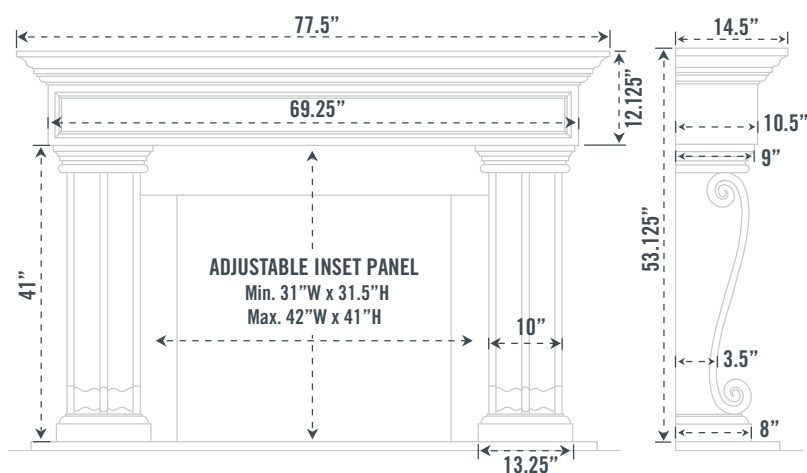

# 1111.555-GS

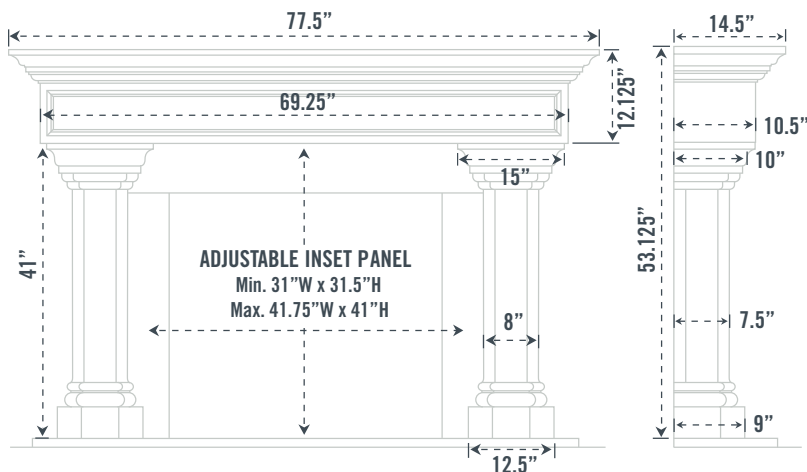

# 1147.556-GS

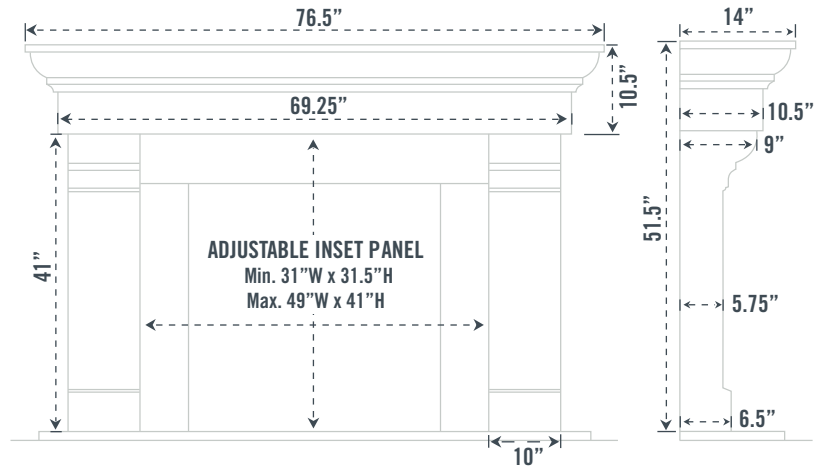

Sophistication and  
timeless elegance  
adding charm to  
any room



1147.511-GS SHOWN IN NATURAL

# 1147.511-GS

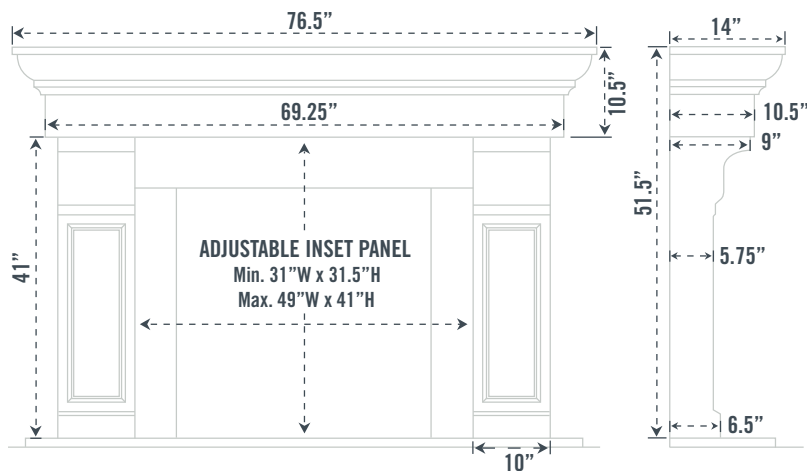

# 1147.536-GS

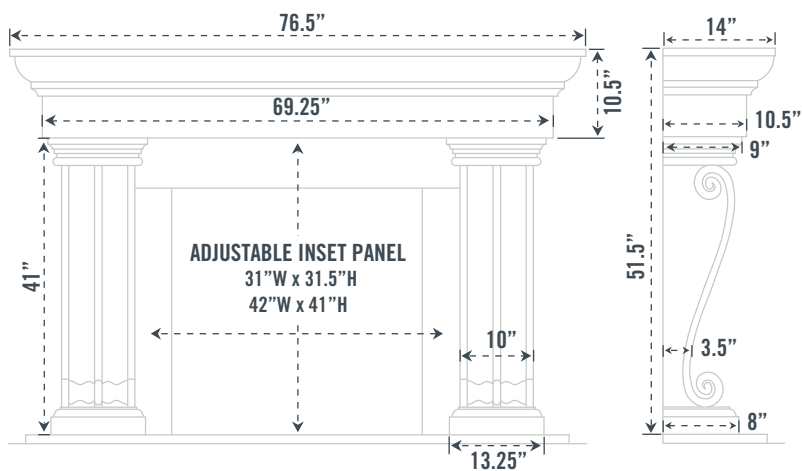

# 1147.555-GS

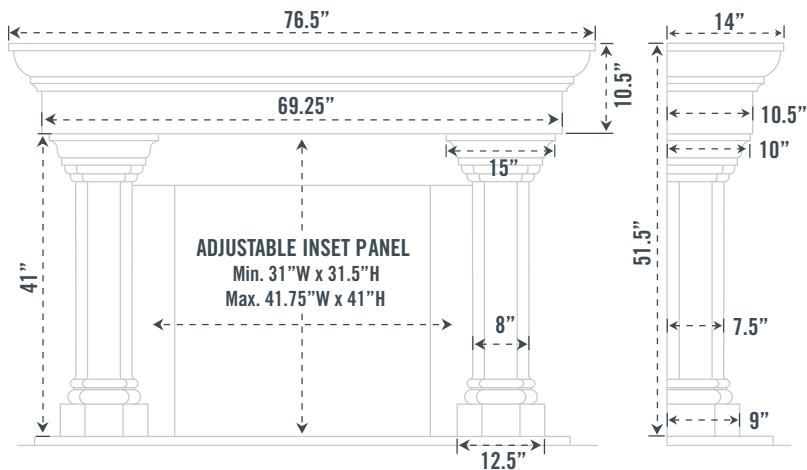

# HEARTHES

Along with our standard 1" hearths, Omega manufactures custom seamless hearths in any size, height and shape to accommodate any space. Available with standard square edge or optional bevel, half round or OG edges.



BEVELLED HEARTH



SQUARE HEARTH



3/4", 1 1/8" or 2" HALF ROUND HEARTH



3/4" OG HEARTH



3 PIECE HEARTH

1 PIECE HEARTH



RAISED HEARTH

# INSETS

Omega is known for our seamless inset panels, custom made to accommodate all firebox sizes and shapes, whether linear, square or arched. Also available with your choice of standard square edge, or optional bevel, half round or OG edges.



BEVELLED INSET



3/4", 1 1/8" or 2" HALF ROUND INSET



3/4" OG INSET



ARCHED INSET

## ADJUSTABLE INSET PANEL



OPTIONAL RISER PANEL

## SEAMLESS INSET PANEL

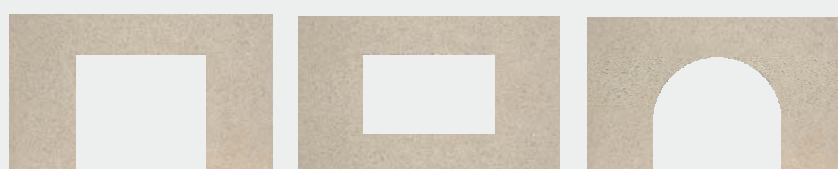

OPTIONAL PICTURE FRAME INSET

# LEG/BRACKET

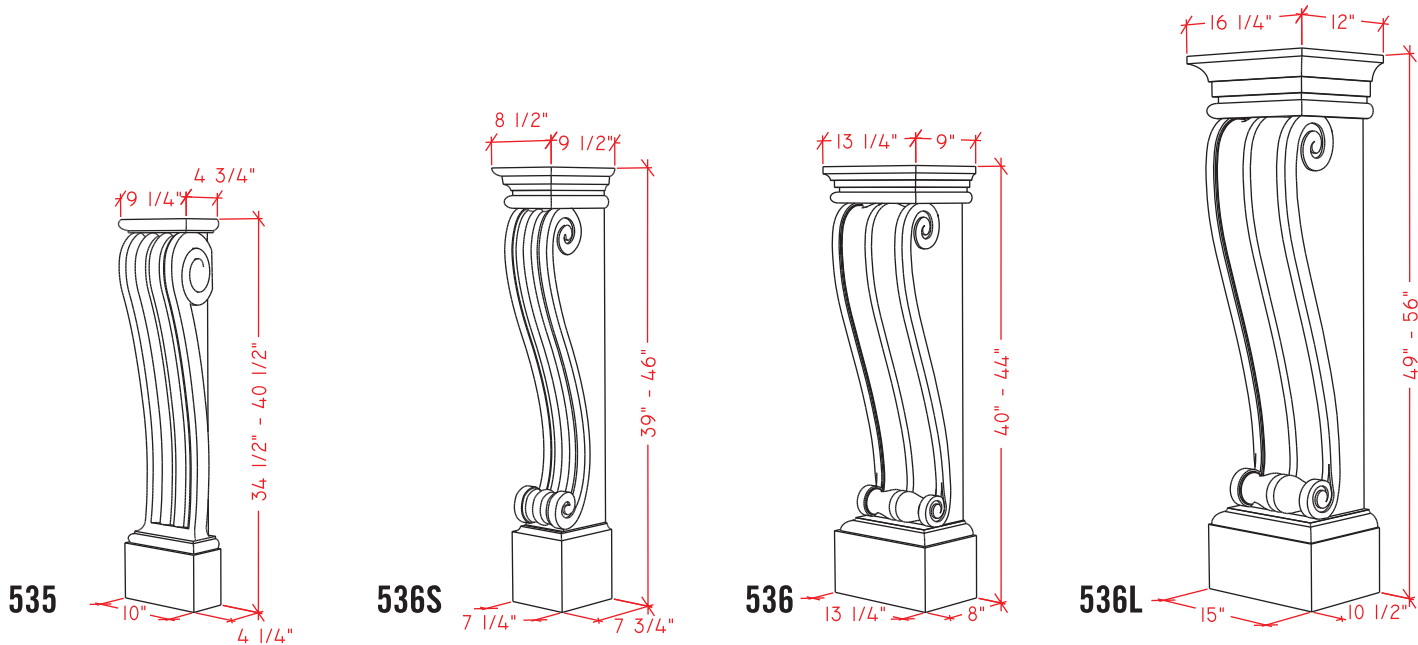
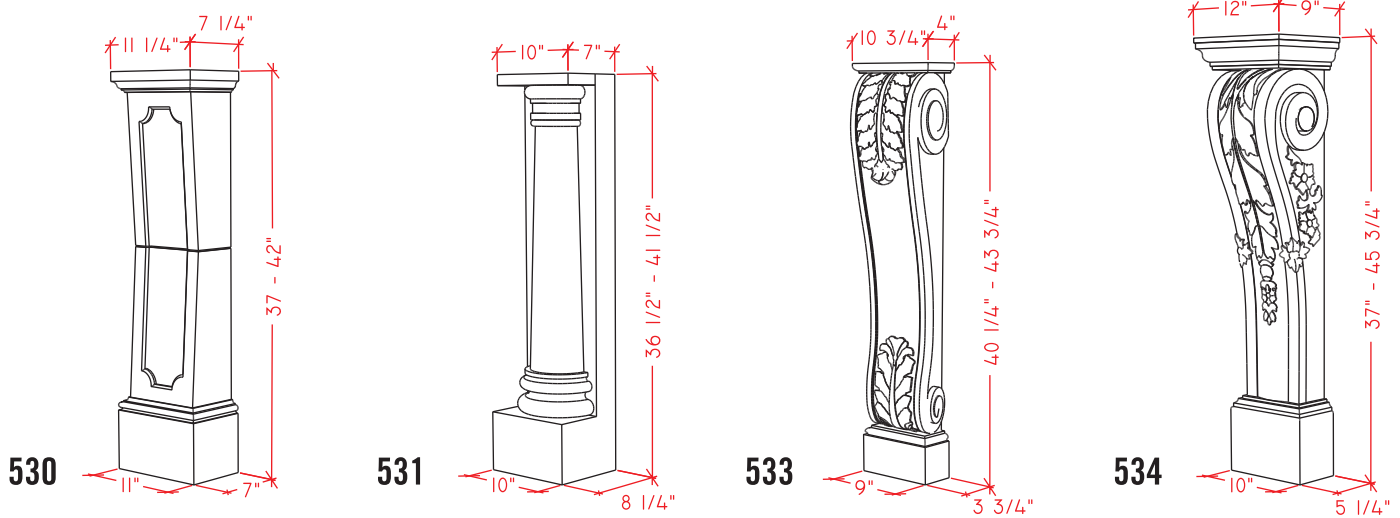
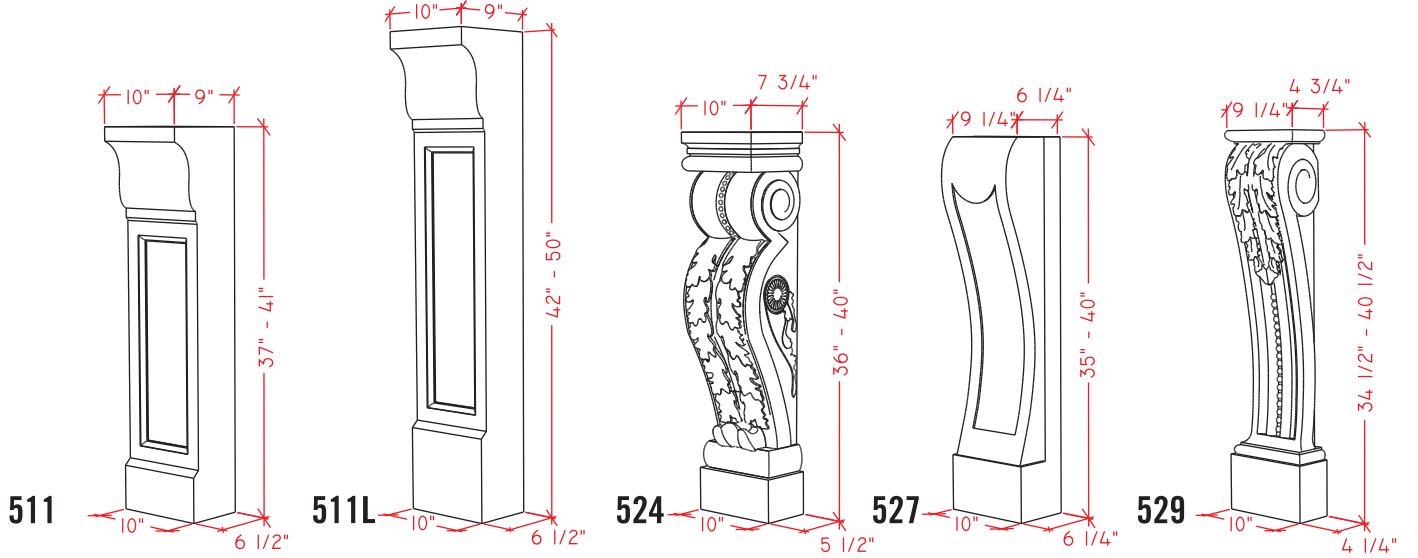

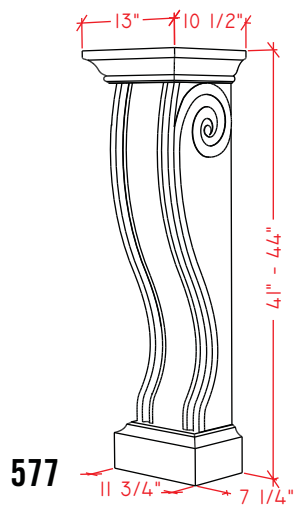
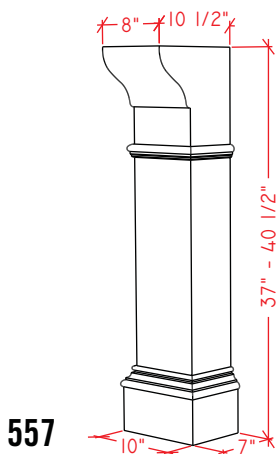
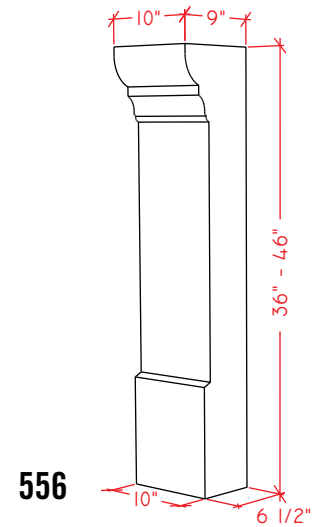
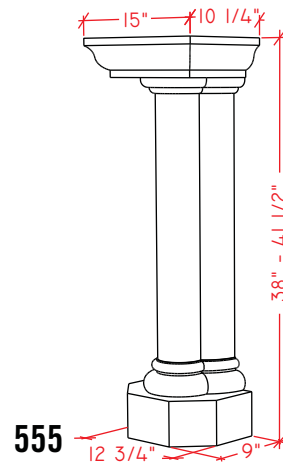
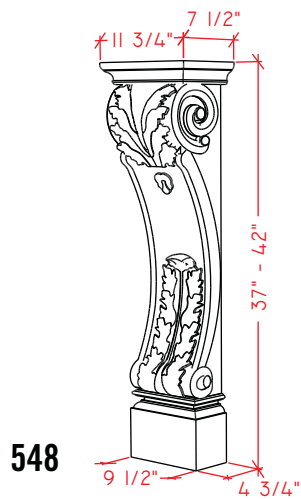
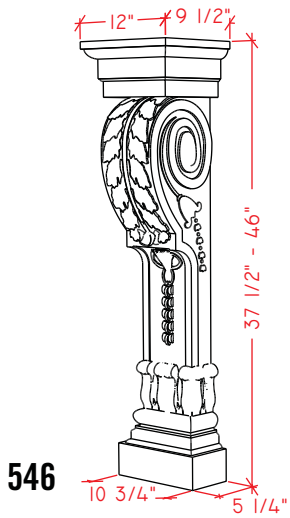
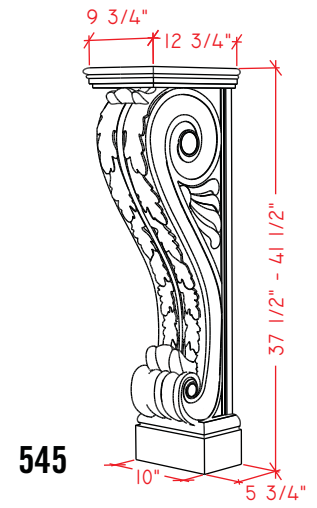
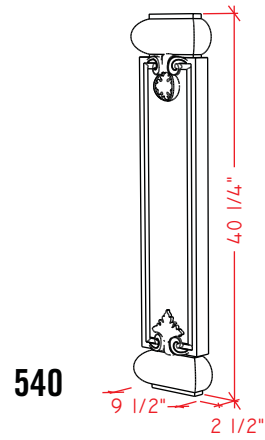
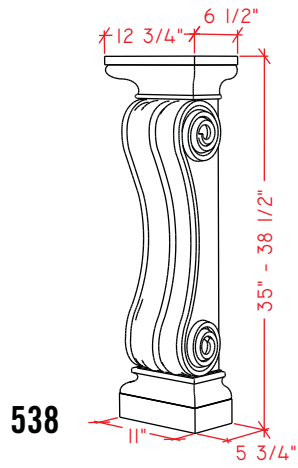
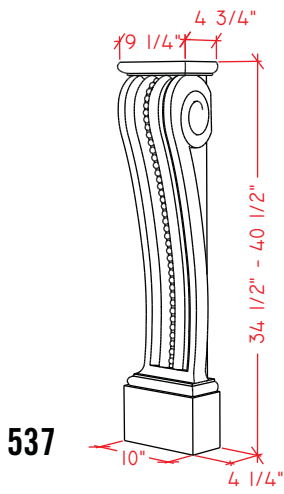

# MANTEL SHELF

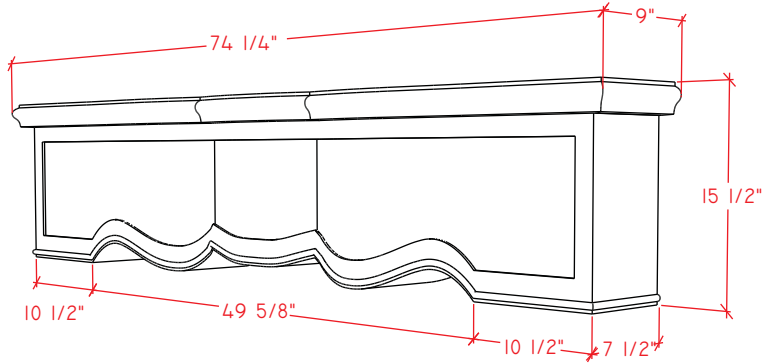

1104

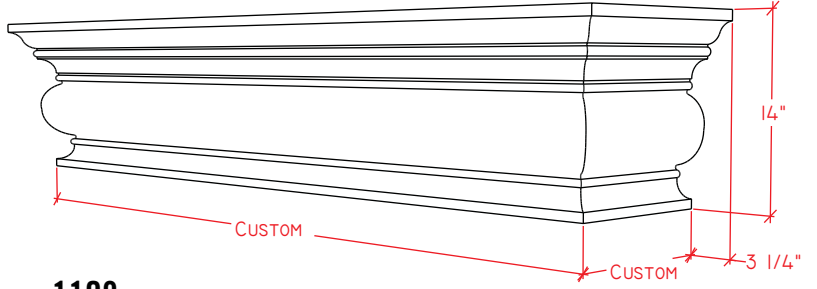

1108

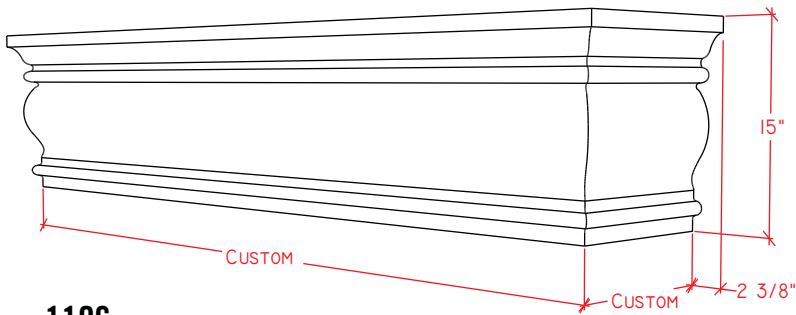

1106

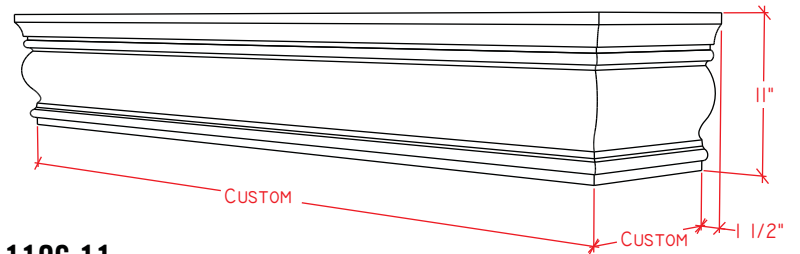

1106.11

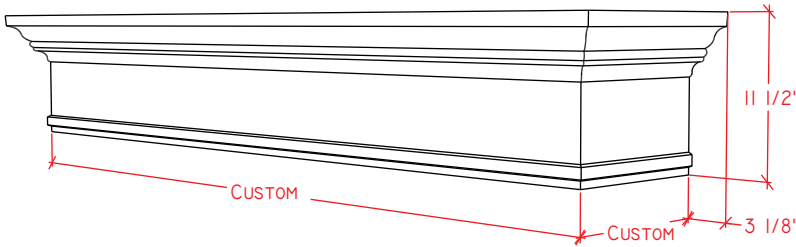

1110

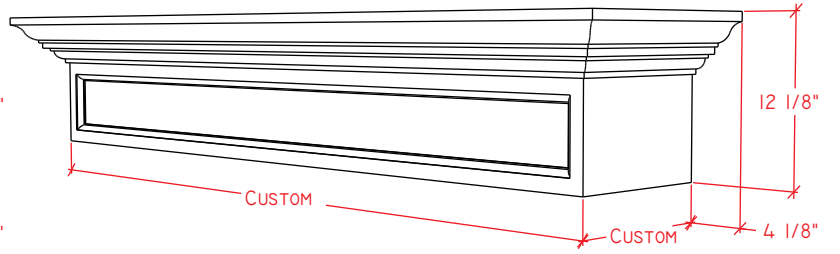

1111

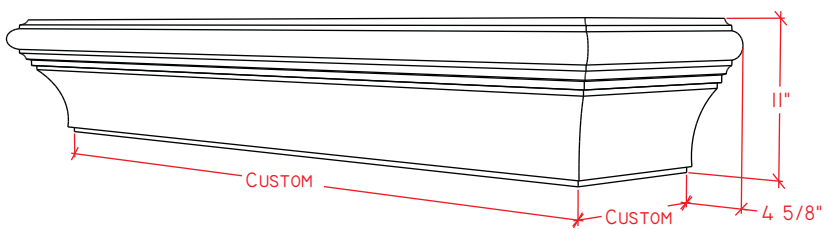

1112

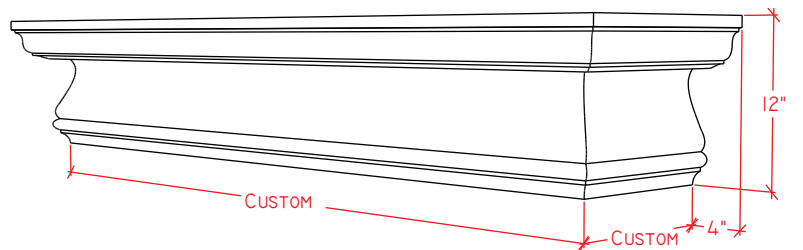

1126



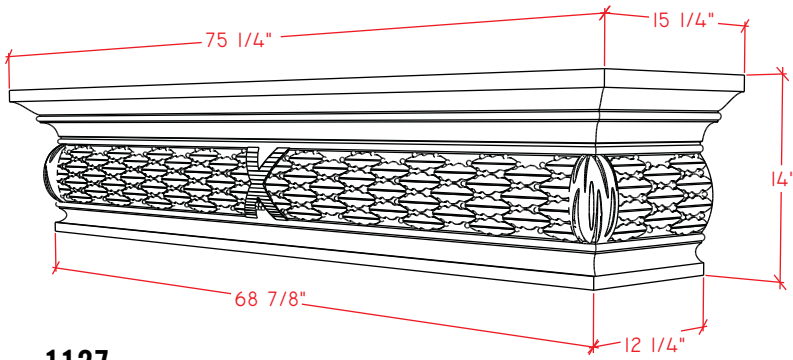

1127

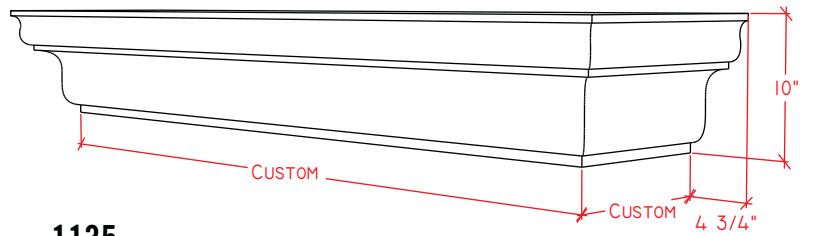

1135

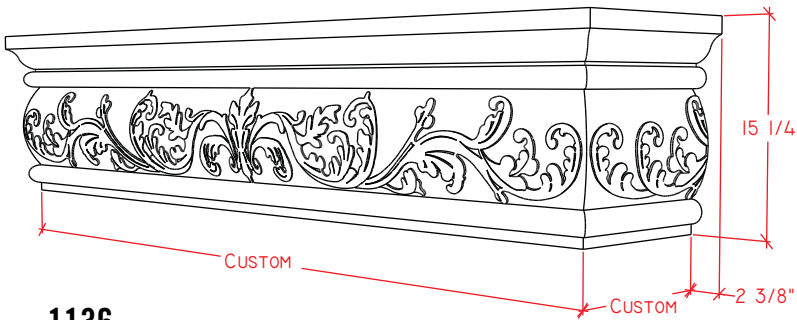

1136

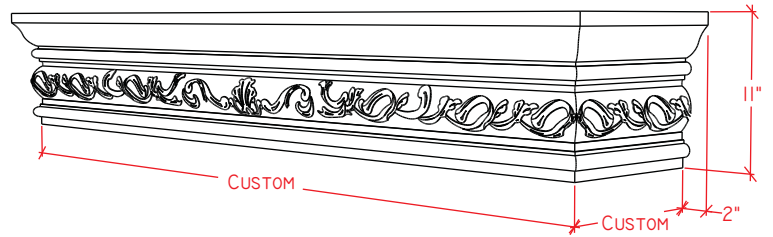

1136.11

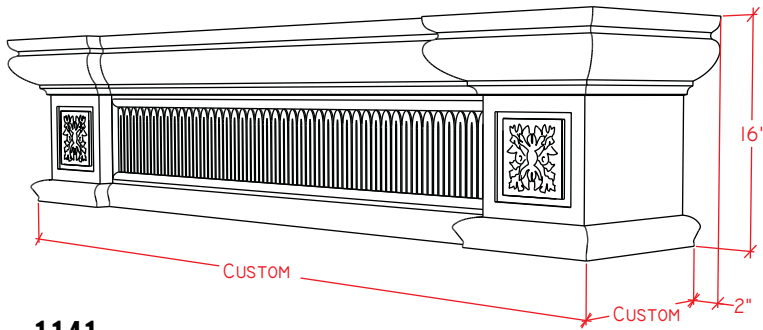

1141

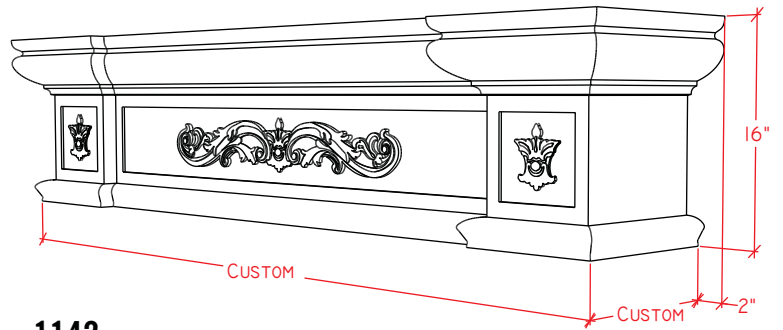

1142

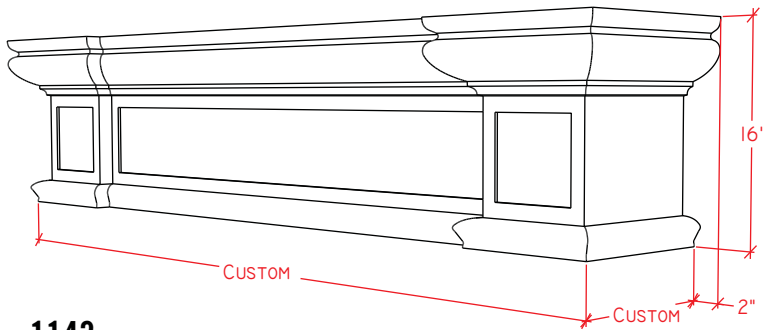

1143

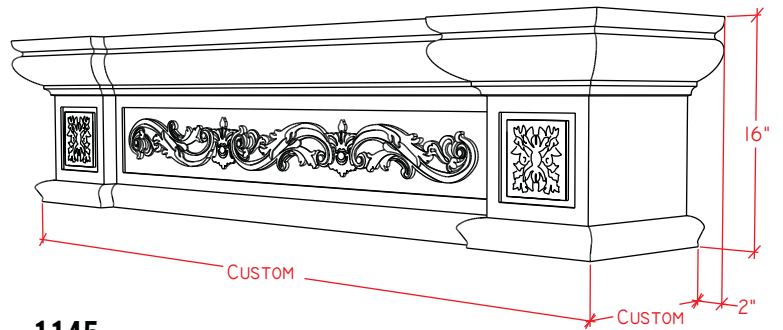

1145

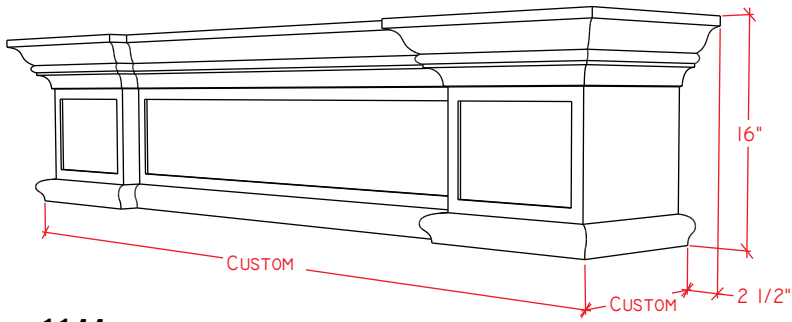

1144

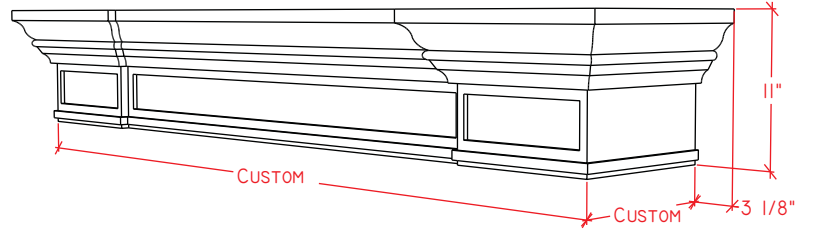

1144.11

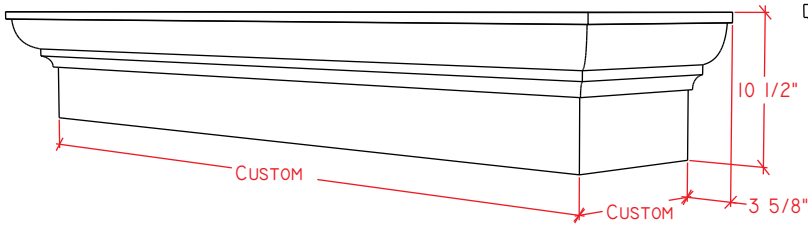

1147

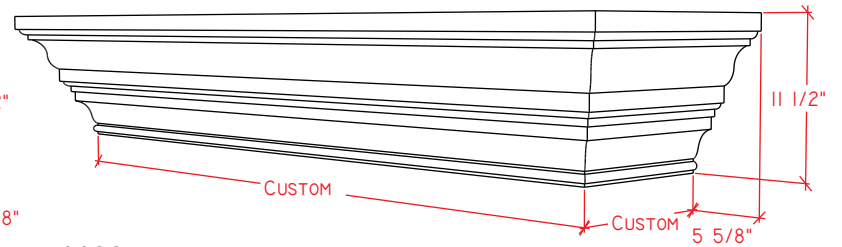

1160

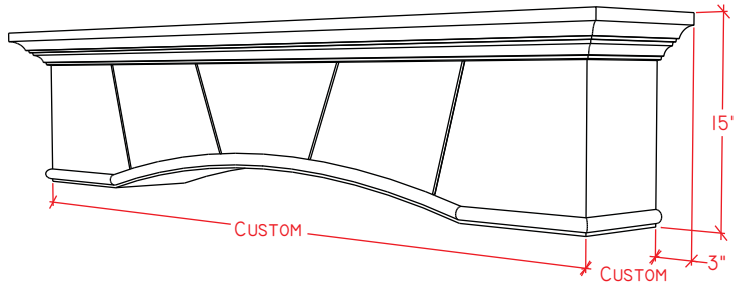

1130.70

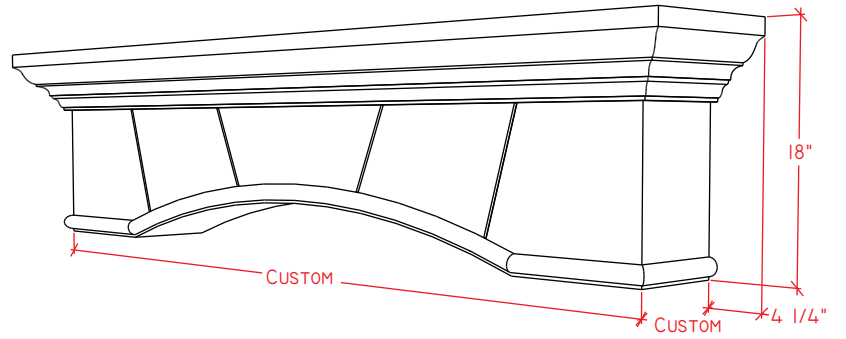

1130.80

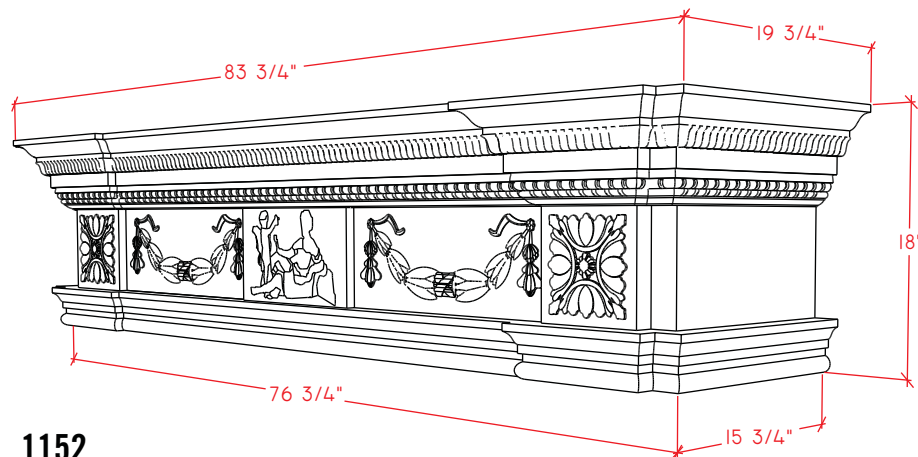

1152

# ANATOMY OF A FIREPLACE

A visual guide to help you identify the different elements that make up a fireplace.

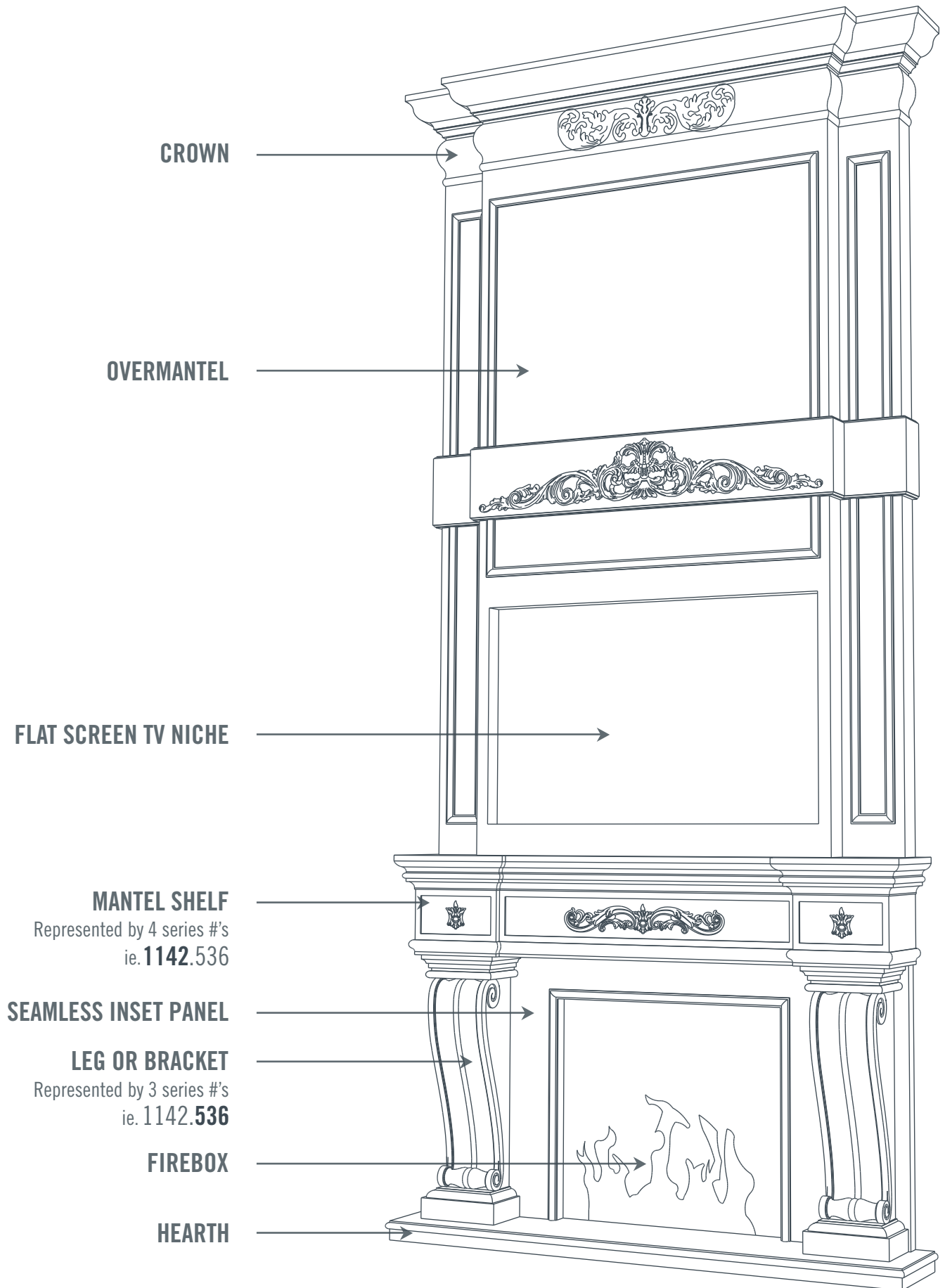

# KITCHEN HOODS

Omega Kitchen Hoods ,, where functionality and luxury meet superb design and old world craftsmanship to create the focal point of any kitchen.





2020.704.81











## CORBELS

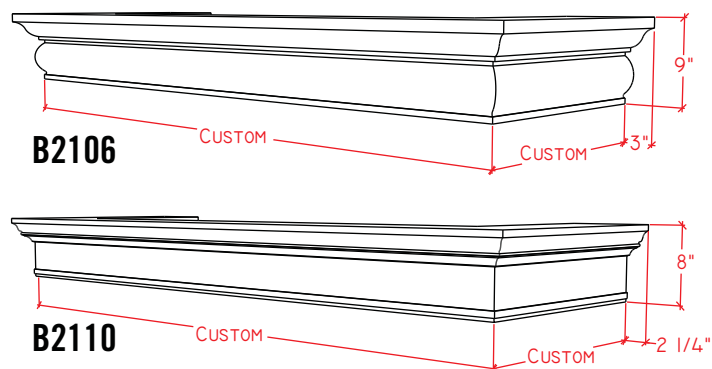
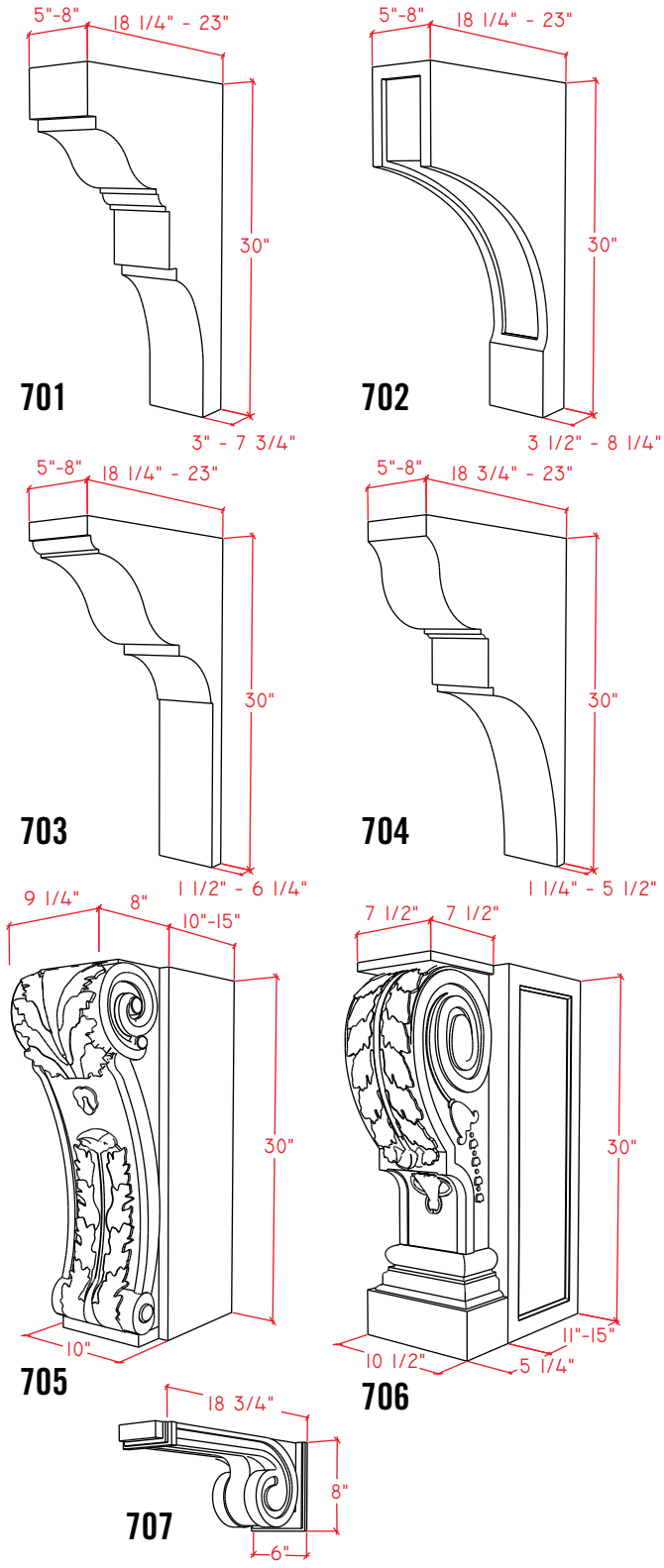

## SHELVES

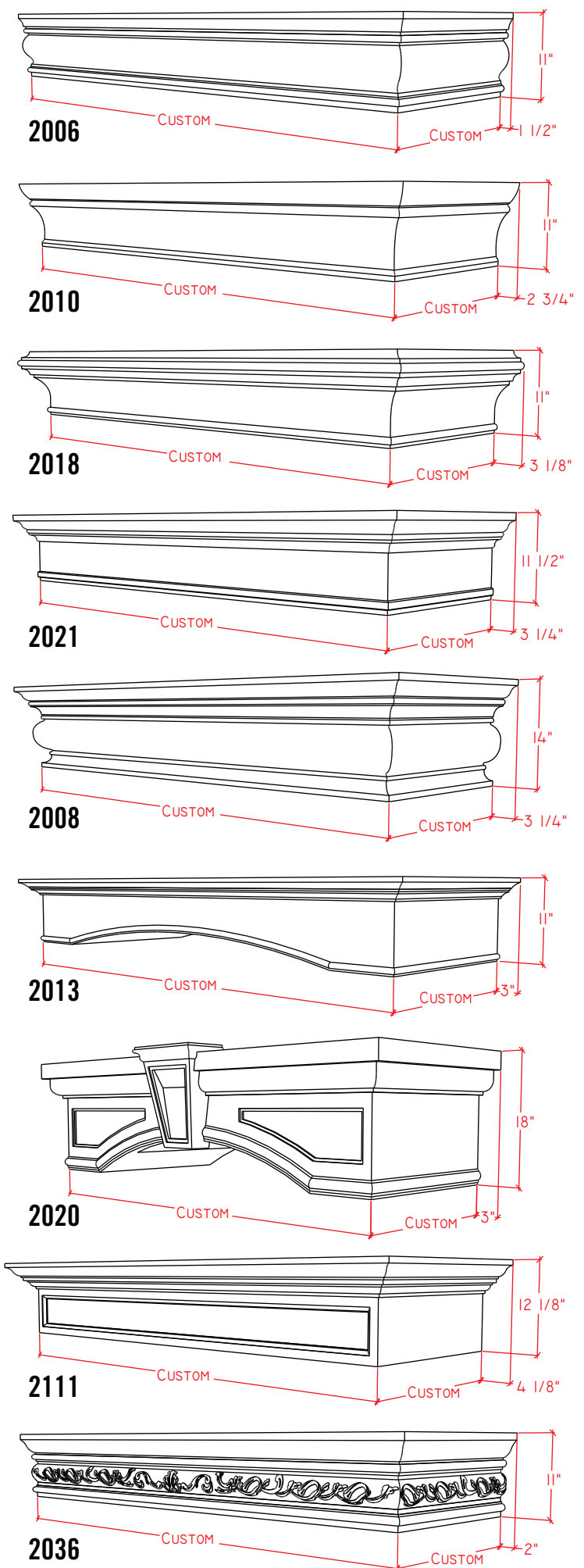

## HOODS

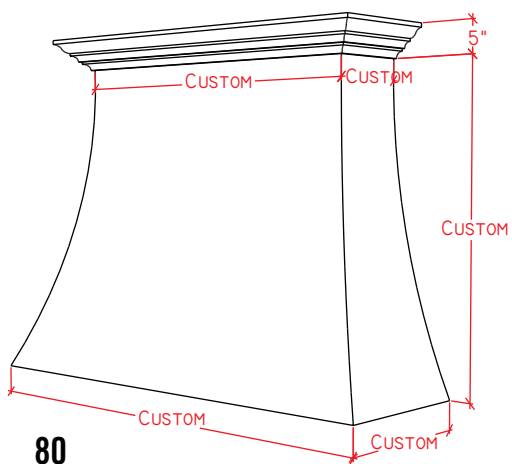

80

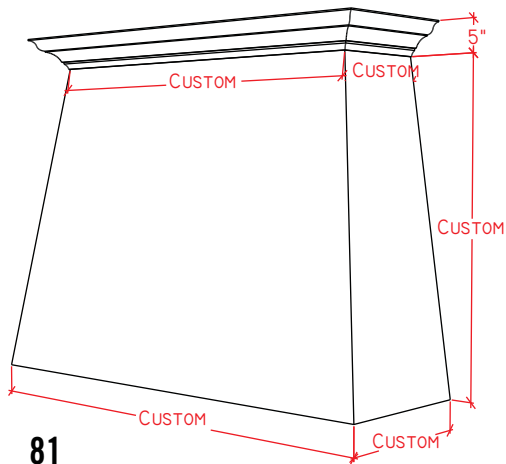

81

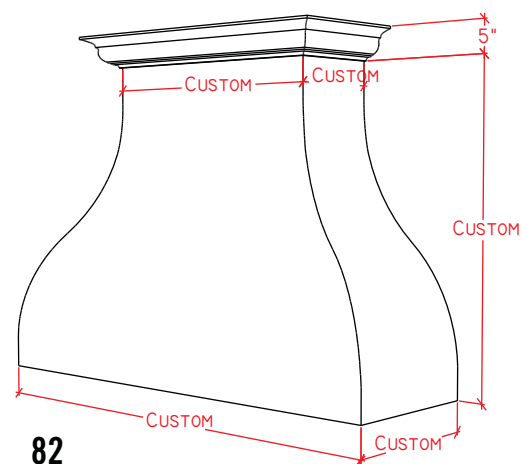

82

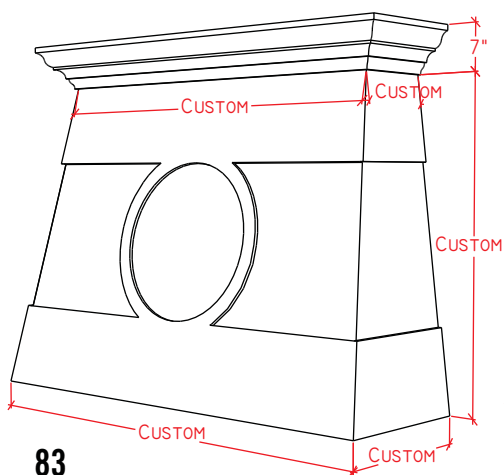

83

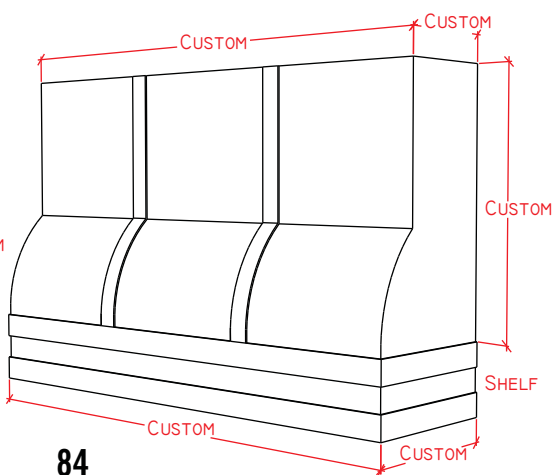

84

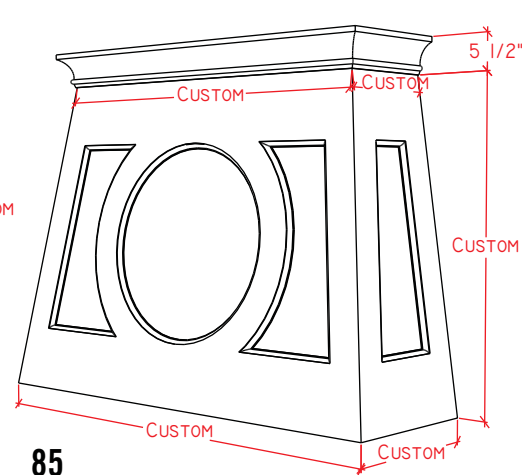

85

## ANATOMY OF A KITCHEN HOOD

Kitchen hood elements contained on these pages are an indicative summary only, please visit [www.omegakitchenhoods.com](http://www.omegakitchenhoods.com) or call toll-free 1-855-712-0123 and our creative team will help you select the correct hood, shelf and corbel to create your unique cast stone hood.

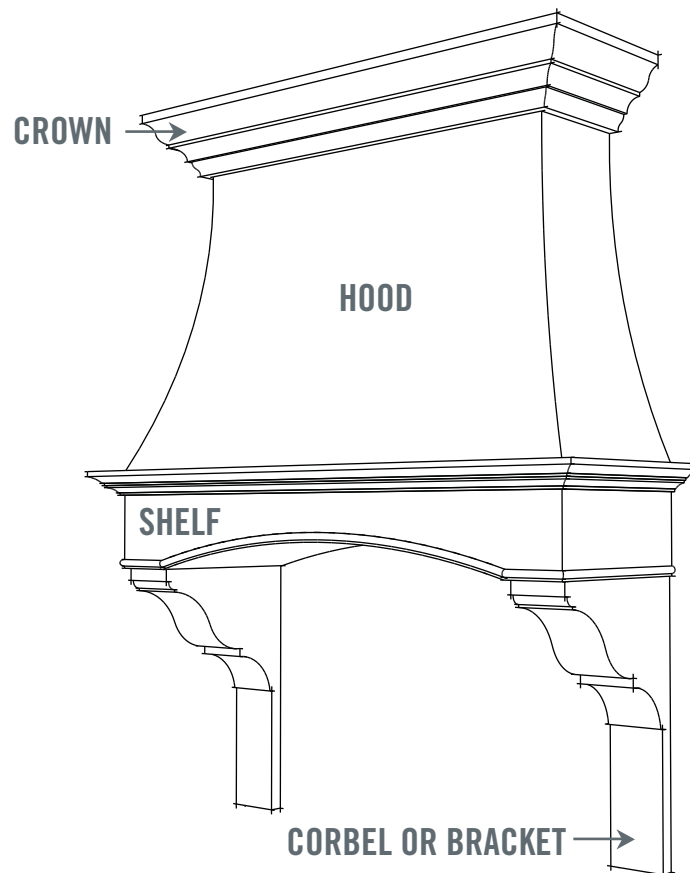

# COLUMNS & PANELS



Adding an architectural element to your space using Omega's columns and panels, available in a multitude of styles, sizes and finishes.





SHOWN IN NATURAL OPEN CAST



SHOWN IN CHOCOLATE HONED





SHOWN IN LIMESTONE OPEN CAST







SHOWN IN LIMESTONE OPEN CAST



SHOWN IN LIMESTONE OPEN CAST

SHOWN IN LIMESTONE OPEN CAST



SHOWN OPEN CAST CUSTOM COLOURS



1100

SHOWN IN PLASTER FAUX PAINT FINISH

## FIREPIT TABLES

Outdoor living and entertaining has quickly become an integral part of our daily lives. Complete your outdoor space by adding an Omega FirePit table where it is sure to become the focal point of any outdoor setting. Available in a variety of styles, sizes and colours, you are certain to find one that suits your needs - [www.omegafirepits.com](http://www.omegafirepits.com)



FP.705



FP.704



FP.703



FP.701





## 3D WALL PANELS



SHOWN IN PLASTER PAINTED

Adding dimension, texture, and visual interest to a wall or space has never been so easy!

Omega 3D wall systems can easily transform any room or space, by customizing and creating unique design combinations and textural patterns. Reinventing spaces, with Omega 3D wall systems.

[www.omega3dwall.com](http://www.omega3dwall.com)



SHOWN IN PLASTER PAINTED





Suitable for home, office or commercial applications, Omega 3D wall panels are sure to enhance any space and create a dramatic focal point. Decorative 3D wall panels will add bold new dimensions, texture and depth to any ordinary room. Endless possibilities with Omega 3D wall panels,,, from surrounding your fireplace or completing your kitchen backsplash, to accenting any simple wall,,, create your own unique work of art!!!

# FEATURE MOULD





Omega's signature Feature Mould panels will enhance your living space, and infuse new breath into any room. Decorative panels can be created for both indoor and outdoor applications. The possibilities are limitless - [www.omegafeaturemould.com](http://www.omegafeaturemould.com)







# PRODUCT CARE AND MAINTENANCE

## PRODUCT SURFACE

Natural stone is a porous surface so stains may develop if spills are not removed immediately. To further protect the grout joints and the surfaces it is strongly recommended that all new cast stone products be sealed after installation.

## SELECTING SEALERS

Always use a high quality sealer that can be purchased from local retail tile and stone stores. It is recommended that you test any new sealer on an inconspicuous spot to ensure that you are satisfied with the outcome before sealing the entire surface area. When applying a sealer make sure that all surfaces are clean and dry and then carefully follow the instructions provided on the product packaging.

## CLEANING

Cast stone should be cleaned regularly to avoid dust and dirt build up. You can easily clean the surface with just warm water and a clean white towel. If the surface has become soiled, you may use a solution of 1 part mild detergent, such as 409, with 3 parts warm water. Thoroughly rinse the entire area with clean warm water to remove any detergent residue. If you require a stronger cleanser, retail home stores or stone and tile stores sell general purpose stone cleaners. Do not use products containing acids or alkaline as they may damage the surface of the stone.

## HANDLING SPILLS

A spill should be cleaned up immediately by carefully blotting the spill with a paper towel or clean white rag. Do not “wipe” a spill as this may force a potential stain deeper into the surface of the stone. A neutral cleanser and cold water can then be used to clean the surface. A persistent stain may be treated with a chemical poultice.

## HOW TO BEST PREVENT COMMON STAINS

### CLEANERS

Do not use acidic or alkaline based products when cleaning stone as this may etch the surface. It is best to use a solution of warm water and mild detergent and a clean white cloth.

### PLANTS

Even a sealed stone surface can get water damage so it is best not to place plants directly onto the stone.

### CANDLES

It is very difficult to remove wax from the surface of cast stone so it is best to have a plate or other container under your candles to catch any dripping wax.

### SMOKE

Smoke can stain a cast stone surface so be careful with your fireplace ventilation system.

### FOOD

Foods containing oils can stain cast stone so it is best to avoid placing food anywhere near the stone surface.

### BEVERAGES

Although liquid spills can generally be cleaned up without damage if caught early and blotted dry, it is best to prevent accidental spills by not placing cups or glasses containing liquid near stone surfaces.

### BURNT LOGS/SPARKS

You should exercise caution when pushing burning logs around in a wood burning fireplace as sparks can etch the surface of the stone when they land. Also, when cleaning the inside of your fireplace, always cover the stone surface to avoid unsightly soot stains.

## CONDITIONS OF SALE FOR STONE PRODUCTS

All cast stone, honed & polished products have a degree of expected variation in shade, texture and veining. These characteristic markings are all part of the stone and are to be expected.

# COLOURS & FINISHES

Omega Mantel's collection of colours and finishes.

**CAST STONE**



**BUFF**



**LIMESTONE**



**NATURAL**



**GRAY**

**DIAMOND STONE**



**PEARL**



**CHOCOLATE**



**SAHARA**



**ASH**

**HONED (POLISHED)**



**CHOCOLATE**



**GRAY**



**SLATE**



**PEARL**



**SAHARA**



**ASH**



**PEARL VEINED**



**SAHARA VEINED**



**ASH VEINED**

